

APPENDIX F – FIGURES

Figure CS-2	Typical Road Cross Section, 20.0 m R.O.W. – Local Road
Figure CS-3	Typical Road Cross Section, 22.0 m R.O.W. – Collector Road
Figure CS-4	Typical Road Cross Section, 22.0 m R.O.W. – Collector Road with Blvd
Figure CS-5	Typical Road Cross Section, 20.0 m R.O.W. – Semi Urban Development
Figure D-1	Urban Residential Driveway Entrance without Sidewalk
Figure D-2	Industrial Driveway Entrances
Figure D-3	Urban Residential Driveway – Concrete with Sidewalk
Figure D-4	Urban Residential Driveway – Asphalt with Sidewalk
Figure D-5	Urban Residential Driveway – Brick Pavers with Sidewalk
Figure D-6	Urban Residential Entrance
Figure D-7	Urban, Industrial, Commercial and Apartment Entrance
Figure E-1	Standard Street Lighting LED Source
Figure E-2	Decorative Acrylic Street Lighting LED Source
Figure E-3	Decorative Acrylic Street Lighting LED Source
Figure E-4	Decorative Glass Street Lighting LED Source
Figure E-5	Decorative Glass Street Lighting LED Source
Figure E-6	Street Lighting Standard Pole
Figure E-7	Street Lighting Decorative Pole
Figure E-8	Street Lighting Standard Arm
Figure LG-1	Lot Grading and Service Sheet
Figure LG-2	Lot Grading and Service Sheet
Figure L-1	Sanitary and Storm Sewer Cleanout
Figure L-2	Private Service Connections Bedding and Backfill
Figure L-3	Rear Yard Catch Basin
Figure L-4	Lot Service Locations
Figure L-5	Footing Drain, Sump Pump and Discharge Pipe Details
Figure L-6	Lot Grading and Drainage
Figure L-7	Trench for Hydro, Bell, Cable TV Services
Figure L-8	Internal Water Meter
Figure L-9	Downspout Discharge Pipe Support
Figure L-10	Water Sampling Station
Figure L-11	Typical Sanitary Pump Station – Cross Section
Figure L-12	Typical Sanitary Pump Station – Plan Views
Figure R-1	Typical Stop Bar and Crosswalk Pavement Markings
Figure R-2	Typical Community Mailbox Car Bay
Figure R-3	Wood Fence Detail
Figure S-1	Sampling Manhole
Figure S-2	Precast Concrete Catch Basin (with Goss Gully Trap)
Figure S-3	Precast Concrete Catch Basin (with Filter Cloth)
Figure S-4	Bedding for Sanitary Sewers
Figure S-5	Concrete Sidewalk
Figure SP-1	Typical Industrial/ Commercial Site Plan Requirements
Figure W-1	Backflow Prevention
Figure W-2	Backflow Prevention with Water Meter
Figure W-3	#9800 Automatic Flushing Device

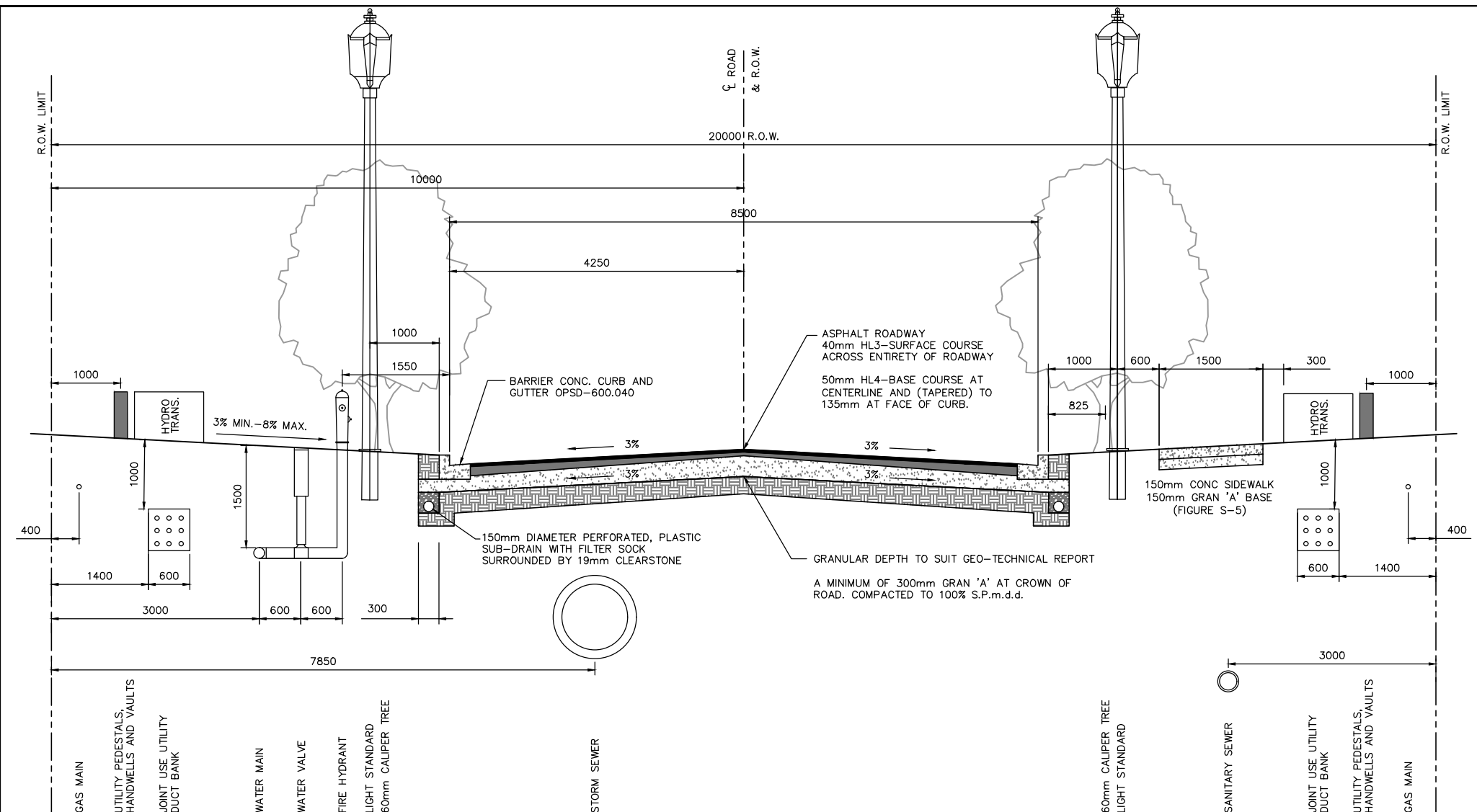

ADDITIONAL NOTES:

1. FINAL LOCATION OF UTILITIES MAY VARY DEPENDING ON UTILITY COMPANY AND ON SITE SPECIFIC REQUIREMENTS. FINAL POSITIONING OF UTILITY INFRASTRUCTURE SHALL BE VERIFIED BY A REPRESENTATIVE OF THE TOWN OF LAKESHORE.
2. 3.0m MULTI-USE PATHWAYS (75mm ASPHALT THICKNESS ON 250mm GRANULAR 'A') MAY BE REQUESTED IN LIEU OF CONCRETE SIDEWALK. THE BASE IS TO BE 300mm WIDER THAN THE ASPHALT ON EACH SIDE. MINIMUM HL4 BASE COURSE ASPHALT IS TO BE USED.
3. ALL SANITARY AND STORM SERVICES SHALL INCLUDE A BENTONITE PLUG, TEE AND CLEANOUT AT PROPERTY LINE. ALL CLEANOUTS SHOULD PROJECT 300mm ABOVE FINISHED GRADE FOR INSPECTION. ONCE INSPECTION IS COMPLETE THE CLEANOUT SHOULD BE CUT, CAPPED AND SET TO FINISHED GRADE.
4. WATER SERVICE VALVES TO BE SET AT PROPERTY LINE.
5. EXPOSED SUB-BASE SHALL BE PROOF-ROLLED IN THE PRESENCE OF A GEO-TECHNICAL ENGINEER TO VERIFY SUITABILITY.
6. SPARE CONDUIT SHALL BE INSTALLED WITHIN THE JOINT USE DUCT BANK AS PER TOWN OF LAKESHORE DEVELOPMENT MANUAL.
7. AT LAKESHORE'S DISCRETION, 100mm DIAMETER PERFORATED SUB-DRAIN MAY BE ACCEPTABLE IF INSTALLED WITH GRADE STAKES OR LASER LEVEL.



		7	June 13, 2016
		6	April 30, 2015
		5	November 11, 2014
		4	December 11, 2012
		3	April 14, 2009
9	March 3, 2019	2	January 14, 2008
8	July 6, 2017	1	October 16, 2006
No.	Revision Date	No.	Revision Date

Town of Lakeshore Development Manual

Figure CS-2
 Typical Road Cross Section
 20.0m R.O.W. - LOCAL ROAD

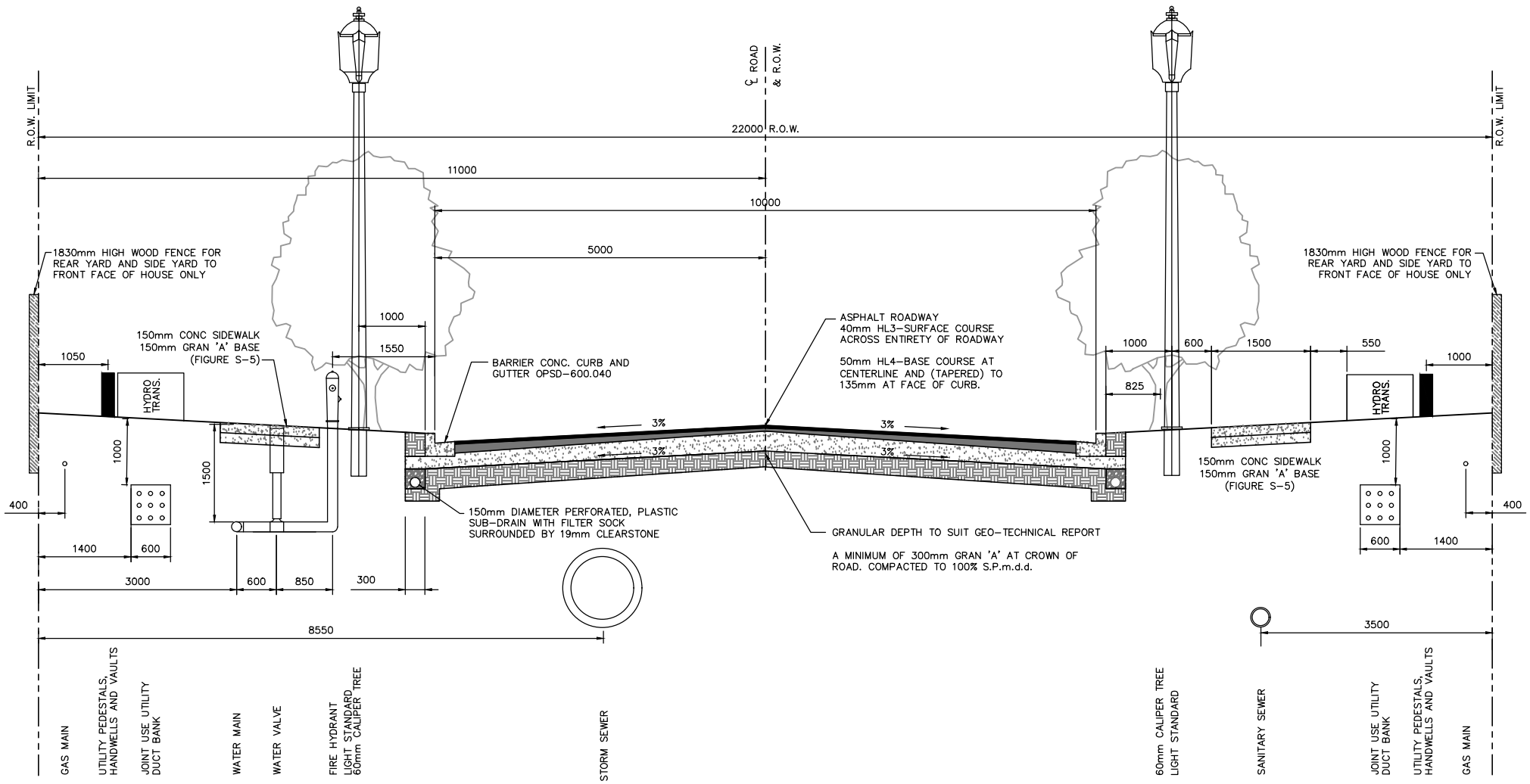

ADDITIONAL NOTES:

- FINAL LOCATION OF UTILITIES MAY VARY DEPENDING ON UTILITY COMPANY AND ON SITE SPECIFIC REQUIREMENTS. FINAL POSITIONING OF UTILITY INFRASTRUCTURE SHALL BE VERIFIED BY A REPRESENTATIVE OF THE TOWN OF LAKESHORE.
- 3.0m MULTI-USE PATHWAYS (75mm ASPHALT THICKNESS ON 250mm GRANULAR 'A') MAY BE REQUESTED IN LIEU OF CONCRETE SIDEWALK. THE BASE IS TO BE 300mm WIDER THAN THE ASPHALT ON EACH SIDE. MINIMUM HL4 BASE COURSE ASPHALT IS TO BE USED.
- EXPOSED SUB-BASE SHALL BE PROOF-ROLLED IN THE PRESENCE OF A GEO-TECHNICAL ENGINEER TO VERIFY SUITABILITY.
- AT LAKESHORE'S DISCRETION, 100mm DIAMETER PERFORATED SUB-DRAIN MAY BE ACCEPTABLE IF INSTALLED WITH GRADE STAKES OR LASER LEVEL.
- SPARE CONDUIT SHALL BE INSTALLED WITHIN THE JOINT USE DUCT BANK AS PER TOWN OF LAKESHORE DEVELOPMENT MANUAL.
- ALL SANITARY AND STORM SERVICES SHALL INCLUDE TEE AND CLEANOUT AT PROPERTY LINE. ALL CLEANOUTS SHOULD PROJECT 300mm ABOVE FINISHED GRADE FOR INSPECTION ONCE INSPECTION IS COMPLETE. THE CLEANOUT SHOULD BE CUT, CAPPED AND SET TO FINISHED GRADE. BENTONITE PLUGS ON ALL SERVICES ARE TO BE COMPLETED BY BUILDER.
- DRIVEWAYS ARE NOT PERMITTED OFF OF COLLECTOR ROADS.
- PRIVATE SERVICES ARE NOT PERMITTED OFF SEWERS AND WATERMAIN ON COLLECTOR ROADS.



		7	June 13, 2016
		6	April 30, 2015
		5	November 11, 2014
		4	December 11, 2012
		3	April 14, 2009
9	March 3, 2019	2	January 14, 2008
8	July 6, 2017	1	October 16, 2006
No.	Revision Date	No.	Revision Date

Town of Lakeshore Development Manual

Figure CS-3
 Typical Road Cross Section
 22.0m R.O.W. - COLLECTOR ROAD

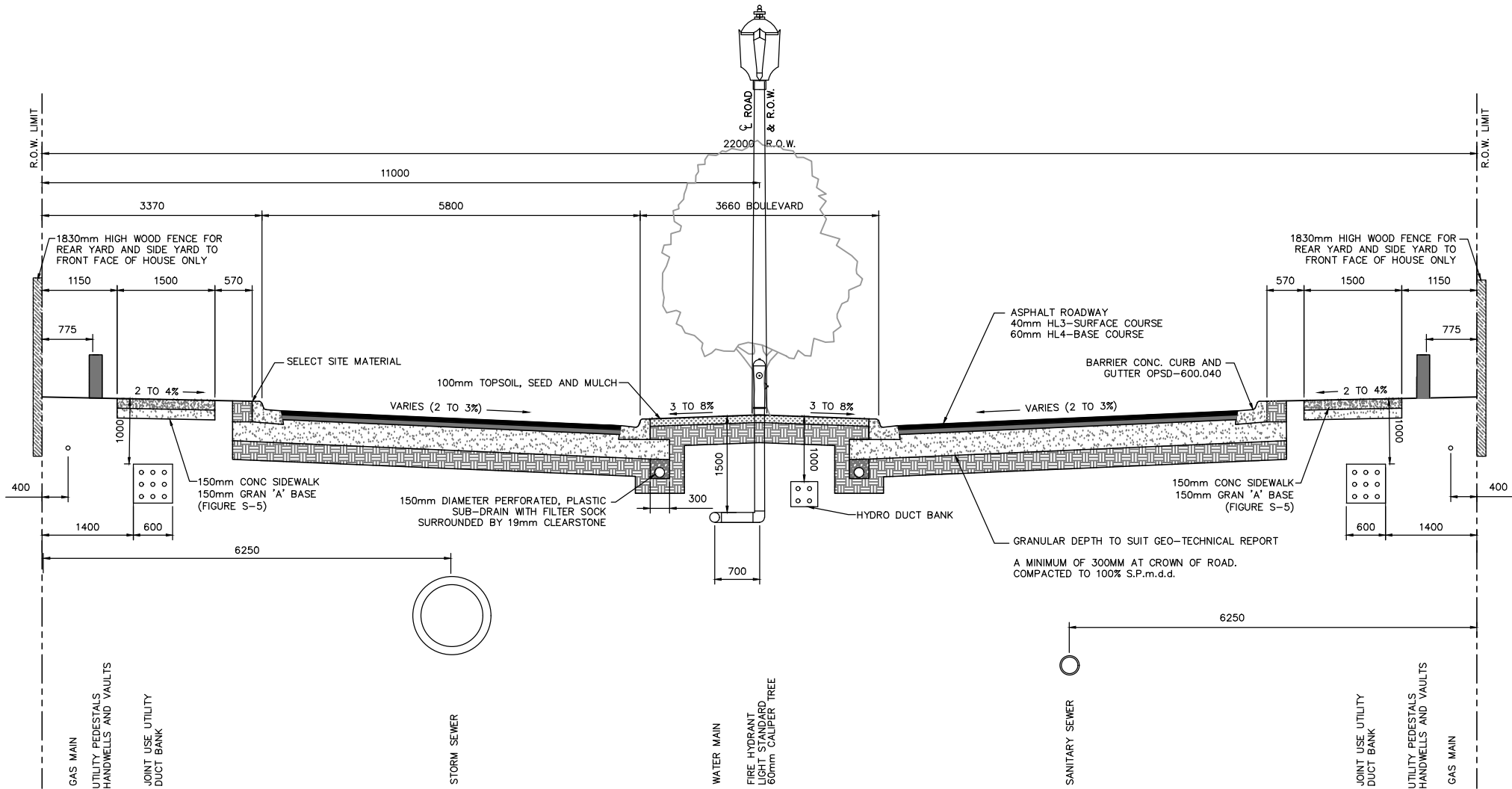

ADDITIONAL NOTES:

- FINAL LOCATION OF UTILITIES MAY VARY DEPENDING ON UTILITY COMPANY AND ON SITE SPECIFIC REQUIREMENTS. FINAL POSITIONING OF UTILITY INFRASTRUCTURE SHALL BE VERIFIED BY A REPRESENTATIVE OF THE TOWN OF LAKESHORE.
- 3.0m MULTI-USE PATHWAYS (75mm ASPHALT THICKNESS ON 250mm GRANULAR 'A') MAY BE REQUESTED IN LIEU OF CONCRETE SIDEWALK. THE BASE IS TO BE 300mm WIDER THAN THE ASPHALT ON EACH SIDE. MINIMUM HL4 BASE COURSE ASPHALT IS TO BE USED.
- EXPOSED SUB-BASE SHALL BE PROOF-ROLLED IN THE PRESENCE OF A GEO-TECHNICAL ENGINEER TO VERIFY SUITABILITY.
- AT LAKESHORE'S DISCRETION, 100mm DIAMETER PERFORATED SUB-DRAIN MAY BE ACCEPTABLE IF INSTALLED WITH GRADE STAKES OR LASER LEVEL.
- SPARE CONDUIT SHALL BE INSTALLED WITHIN THE JOINT USE DUCT BANK AS PER TOWN OF LAKESHORE DEVELOPMENT MANUAL.
- DRIVEWAYS ARE NOT PERMITTED OFF OF COLLECTOR ROADS.
- PRIVATE SERVICES ARE NOT PERMITTED OFF SEWERS AND WATERMAIN ON COLLECTOR ROADS



No.	Revision Date	No.	Revision Date
6	March 3, 2019		
5	July 6, 2017		
4	April 30, 2015		
3	December 11, 2012		
2	January 14, 2008		
1	October 16, 2006		

Town of Lakeshore Development Manual

Figure CS-4
Typical Road Cross Section
22.0m R.O.W. - COLLECTOR ROAD WITH BOULEVARD

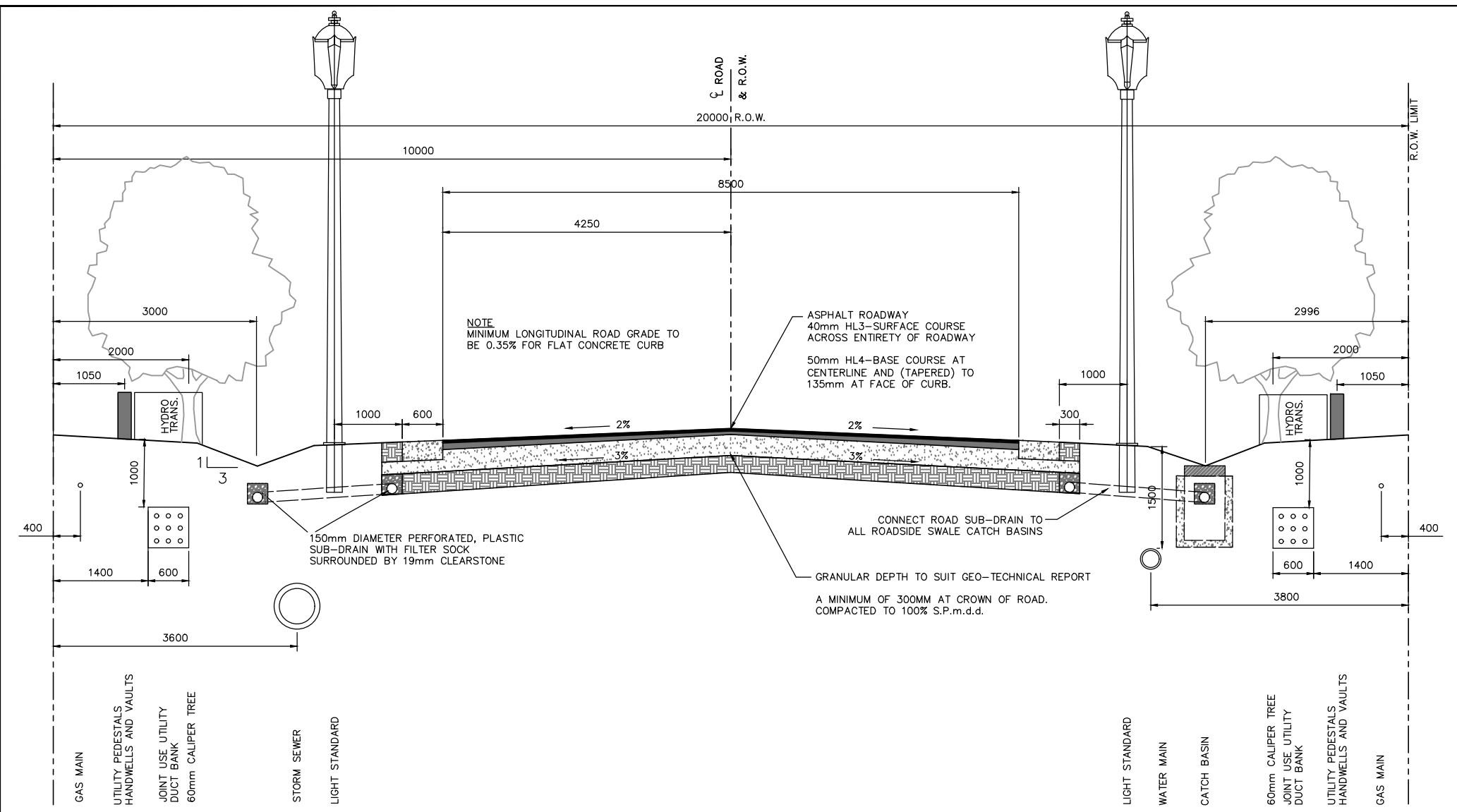

ADDITIONAL NOTES:

1. FINAL LOCATION OF UTILITIES MAY VARY DEPENDING ON UTILITY COMPANY AND ON SITE SPECIFIC REQUIREMENTS. FINAL POSITIONING OF UTILITY INFRASTRUCTURE SHALL BE VERIFIED BY A REPRESENTATIVE OF THE TOWN OF LAKESHORE.
2. 3.0m MULTI-USE PATHWAYS (75mm ASPHALT THICKNESS ON 250mm GRANULAR 'A') MAY BE REQUESTED IN LIEU OF CONCRETE SIDEWALK. THE BASE IS TO BE 300mm WIDER THAN THE ASPHALT ON EACH SIDE. MINIMUM HL4 BASE COURSE ASPHALT IS TO BE USED.
3. ALL SANITARY AND STORM SERVICES SHALL INCLUDE TEE AND CLEANOUT AT PROPERTY LINE. ALL CLEANOUTS SHOULD PROJECT 300mm ABOVE FINISHED GRADE FOR INSPECTION ONCE INSPECTION IS COMPLETE THE CLEANOUT SHOULD BE CUT, CAPPED AND SET TO FINISHED GRADE. BENTONITE PLUGS ON ALL SERVICES ARE TO BE COMPLETED BY BUILDER.
4. WATER SERVICE VALVES TO BE SET AT PROPERTY LINE AT MIDDLE OF LOT.
5. EXPOSED SUB-BASE SHALL BE PROOF-ROLLED IN THE PRESENCE OF A GEO-TECHNICAL ENGINEER TO VERIFY SUITABILITY.
6. SPARE CONDUIT SHALL BE INSTALLED WITHIN THE JOINT USE DUCT BANK AS PER TOWN OF LAKESHORE DEVELOPMENT MANUAL.
7. SUB-DRAINS IN SWALE CAN BE OVERSIZED AND USED AS A STORM SEWER.
8. NO DRIVEWAY CULVERTS ALLOWED IN RIGHT-OF-WAY.



7	July 6, 2017
6	May 1, 2014
5	January 27, 2014
4	December 11, 2012
3	April 14, 2009
2	January 14, 2008
1	October 16, 2006
8	March 3, 2019
No.	Revision Date

Town of Lakeshore Development Manual

Figure CS-5
 Typical Road Cross Section
 20.0m R.O.W. - SEMI-URBAN DEVELOPMENT

NOTES

1. RURAL AND SEMI-URBAN DRIVEWAY REQUIREMENTS ARE DETERMINED ON A CASE BY CASE SCENARIO. PLEASE CONTACT THE TOWN OF LAKESHORE PUBLIC WORKS DIVISION BEFORE PROCEEDING WITH HARD SURFACE OR CURB PLACEMENT WITHIN ROAD RIGHT-OF-WAY.
2. DRIVEWAYS ARE NOT PERMITTED OFF COLLECTOR ROADS.
3. DRIVEWAY LOCATION IS BASED OFF OF FRONTAGE AND SHOULD BE PERPENDICULAR TO PRIVATE SERVICES.
4. LIMIT OF ONE DRIVEWAY PER RESIDENCE.
5. 600mm CURB TAPER ON BOTH SIDES OF DRIVEWAY INCLUDED IN 7.6m. (25') CURB CUT.
6. FOR CONCRETE DRIVEWAYS ONLY - 12mm (½") THICK FULL DEPTH PRE MOLD JOINT FILLER AS PER OPSS 1308
7. FOR CONCRETE DRIVEWAYS ONLY - SAWCUT SLAB TO CONTROL CRACKING.

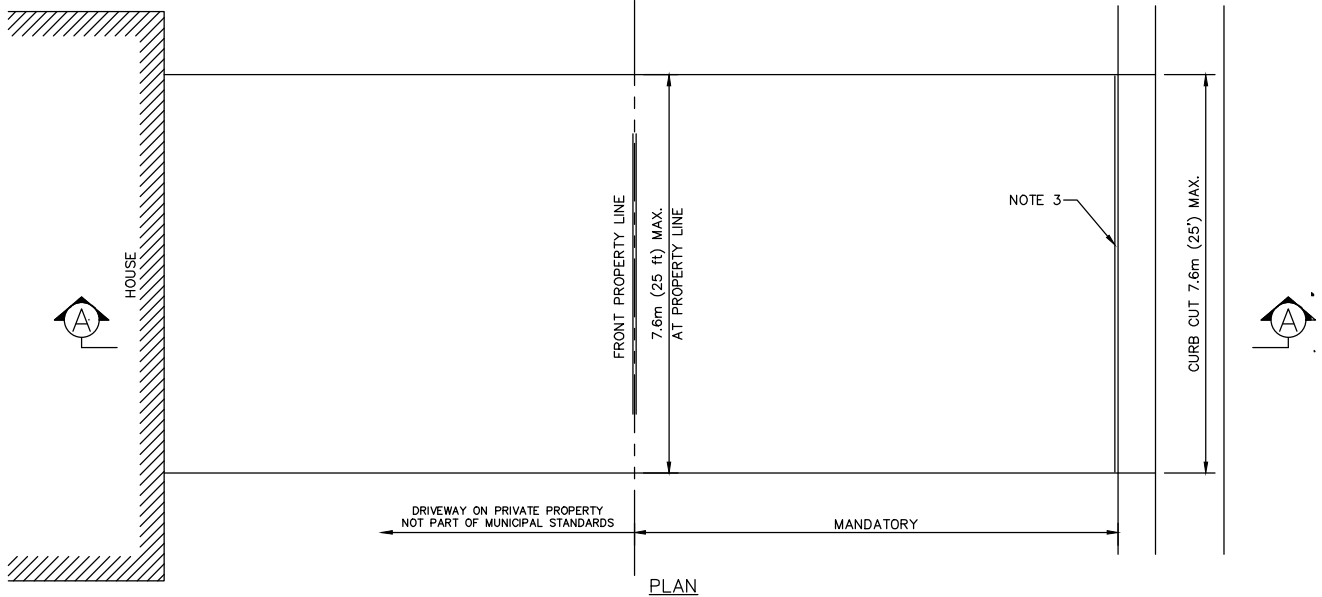

PAVING STONES SECTION A-A

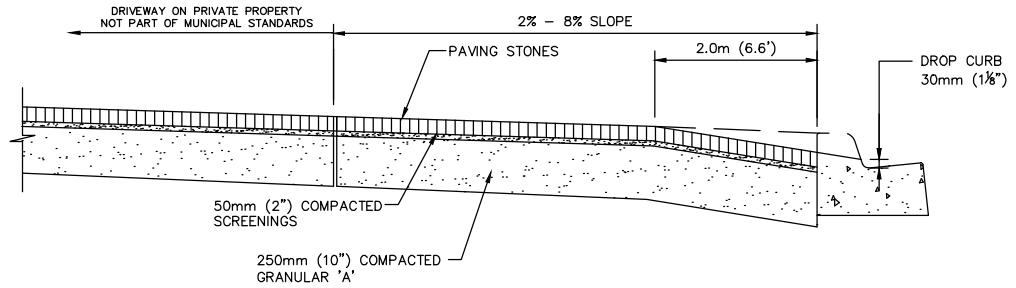

ASPHALT SECTION A-A

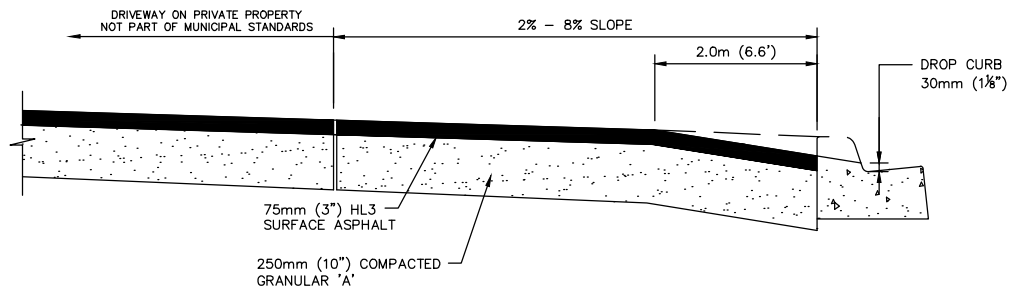

CONCRETE SECTION A-A

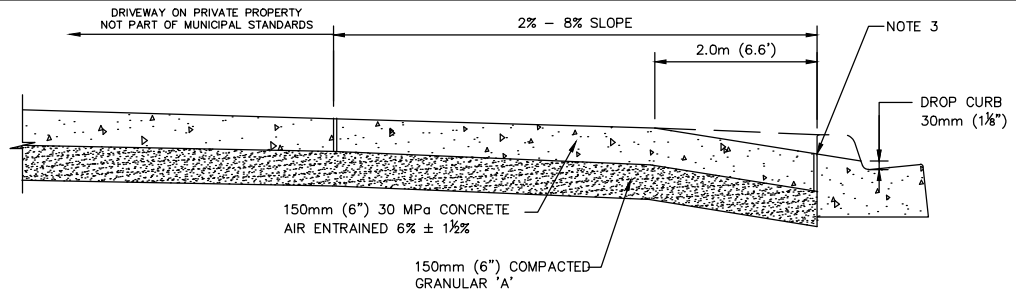

7	March 3, 2019
6	July 7, 2017
5	December 18, 2012
4	December 07, 2011
3	November 18, 2008
2	January 14, 2008
1	October 16, 2006
No.	Revision Date

Town of Lakeshore Development Manual

Figure D-1

URBAN RESIDENTIAL DRIVEWAY ENTRANCE WITHOUT SIDEWALK

DRIVEWAY DIMENSIONS*			
ONE WAY		TWO WAY	
MIN. (m)	MAX. (m)	MIN. (m)	MAX. (m)
5.0	7.0	8.0	12.0

*SEE NOTE 4

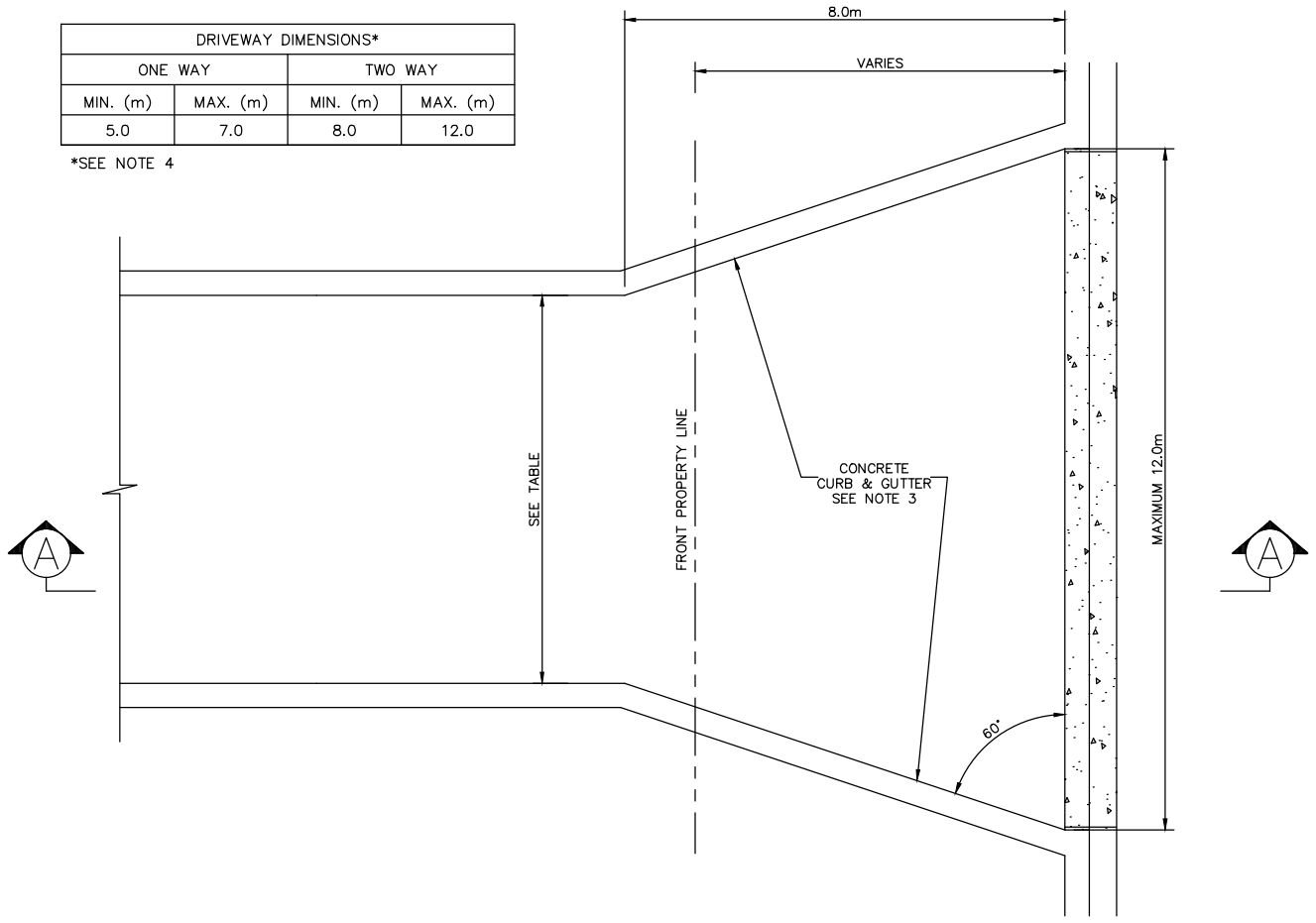

PLAN

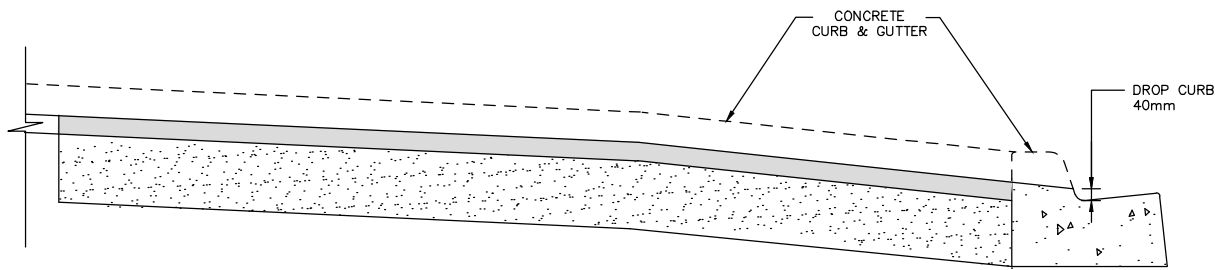

SECTION A-A

NOTES

1. CURB CUT IF REQUIRED, SHALL BE MADE AS DIRECTED BY THE ENGINEER.
2. APPROACH GRADE SHALL NOT EXCEED 8%.
3. CONCRETE CURBING ON DRIVEWAY APRON IS NOT REQUIRED ON RURAL ROADS.
4. ABOVE NOTED DIMENSIONS ARE GUIDELINES. DEVELOPER TO CONFIRM THAT DRIVEWAY WIDTHS AND APRON SIZE ARE SUFFICIENT TO FACILITATE TRUCK AND EMERGENCY VEHICLE TURNING MOVEMENTS.



No.	Revision Date
4	July 7, 2017
3	January 27, 2014
2	January 14, 2008
1	October 16, 2006

Town of Lakeshore Development Manual

Figure D-2

INDUSTRIAL DRIVEWAY ENTRANCES

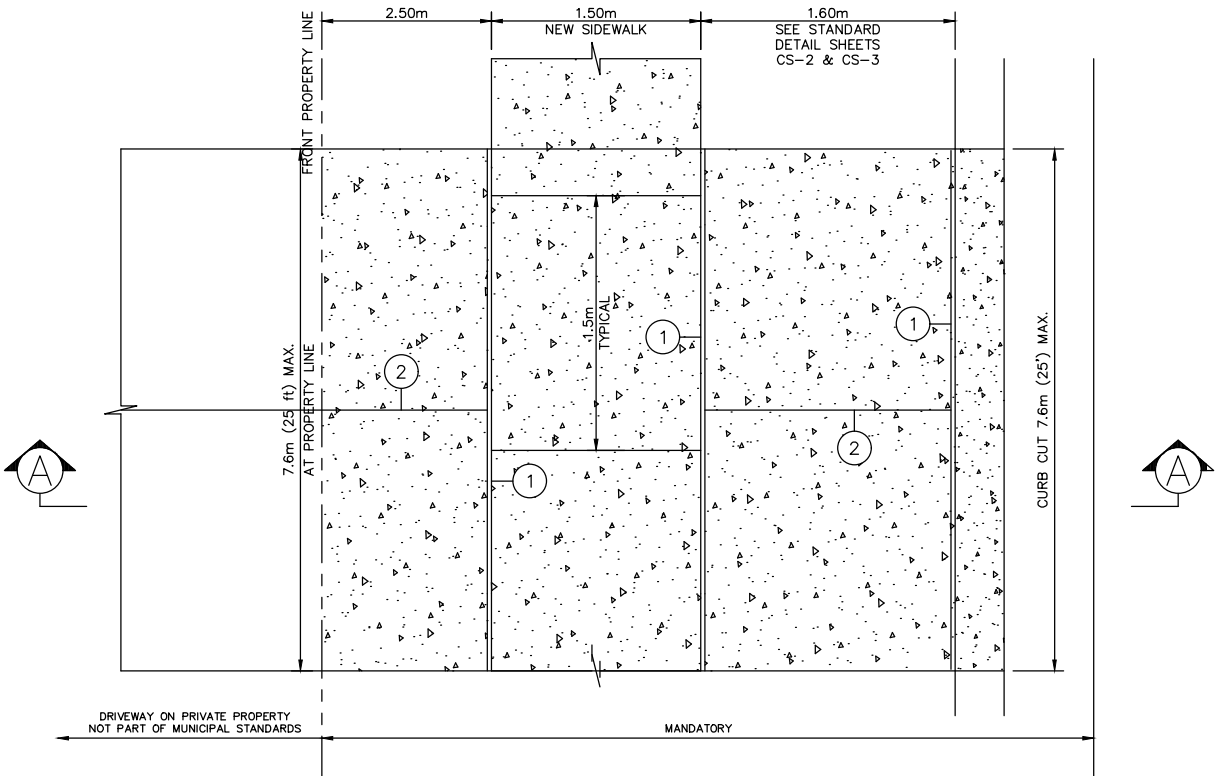

PLAN

Note: Taper included in the 7.6m (25') Curb Cut.

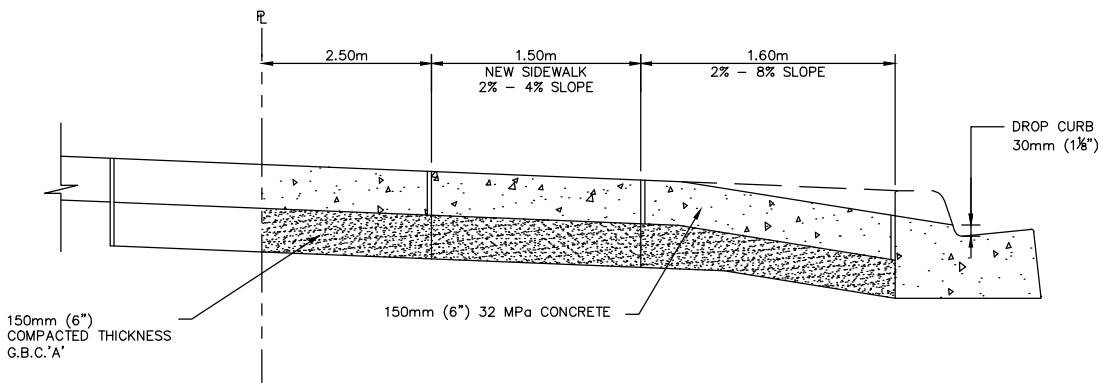

SECTION A-A

NOTES

1. 15mm THICK FULL DEPTH PREMOLDED JOINT FILLER AS PER MTO FORM 1308.
2. 6mm THICK, 50mm DEEP PREMOLDED JOINT FILLER OR SAWCUT IF DRIVEWAY WIDTH EXCEEDS 3.65m.
3. CONCRETE TO BE AIR ENTRAINED 6% ± 1½%.
4. APPROVAL BY A TOWN OF LAKESHORE ENGINEERING MANAGER IS REQUIRED IF APPROACH SLAB EXCEEDS 8% SLOPE.
5. WIRE MESH IS NOT PERMITTED TO BE PLACED WITHIN THE MUNICIPAL SECTIONS OF THE DRIVEWAY, SIDEWALK OR APPROACH.
6. RURAL AND SEMI-URBAN DRIVEWAY REQUIREMENTS ARE DETERMINED ON A CASE BY CASE SCENARIO. PLEASE CONTACT THE TOWN OF LAKESHORE PUBLIC WORKS DIVISION BEFORE PROCEEDING WITH HARD SURFACE OR CURB PLACEMENT WITHIN ROAD RIGHT-OF-WAY.



8	March 3, 2019
7	July 7, 2017
6	June 13, 2016
5	December 18, 2012
4	December 07, 2011
3	April 14, 2009
2	January 14, 2008
No.	Revision Date

Town of Lakeshore Development Manual

Figure D-3
URBAN RESIDENTIAL DRIVE
CONCRETE WITH SIDEWALK

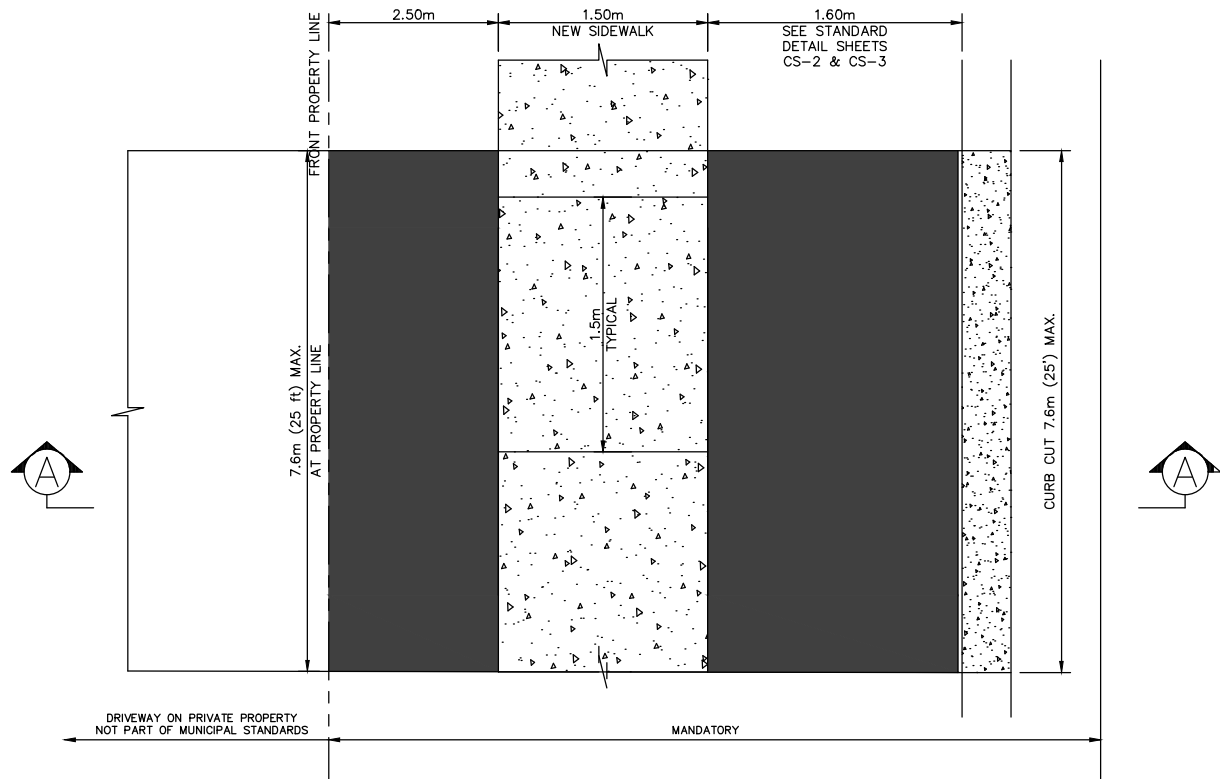

PLAN

Note: Taper included in the 7.6m (25') Curb Cut.

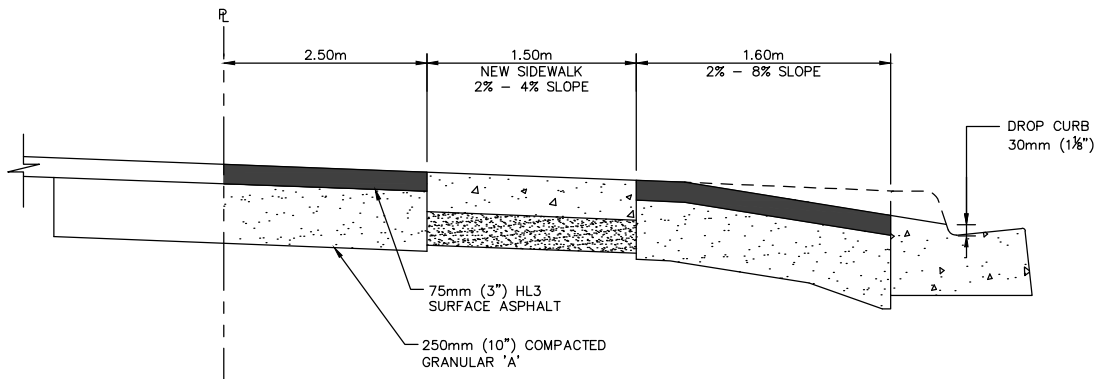

SECTION A-A

NOTES

1. APPROVAL BY A TOWN OF LAKESHORE ENGINEERING MANAGER IS REQUIRED IF APPROACH SLAB EXCEEDS 8% SLOPE.
2. RURAL AND SEMI-URBAN DRIVEWAY REQUIREMENTS ARE DETERMINED ON A CASE BY CASE SCENARIO. PLEASE CONTACT THE TOWN OF LAKESHORE PUBLIC WORKS DIVISION BEFORE PROCEEDING WITH HARD SURFACE OR CURB PLACEMENT WITHIN ROAD RIGHT-OF-WAY.



7	March 3, 2019
6	July 7, 2017
5	June 18, 2016
4	December 18, 2012
3	December 07, 2011
2	January 14, 2008
1	October 16, 2006
No.	Revision Date

Town of Lakeshore Development Manual

Figure D-4
URBAN RESIDENTIAL DRIVE
ASPHALT WITH SIDEWALK

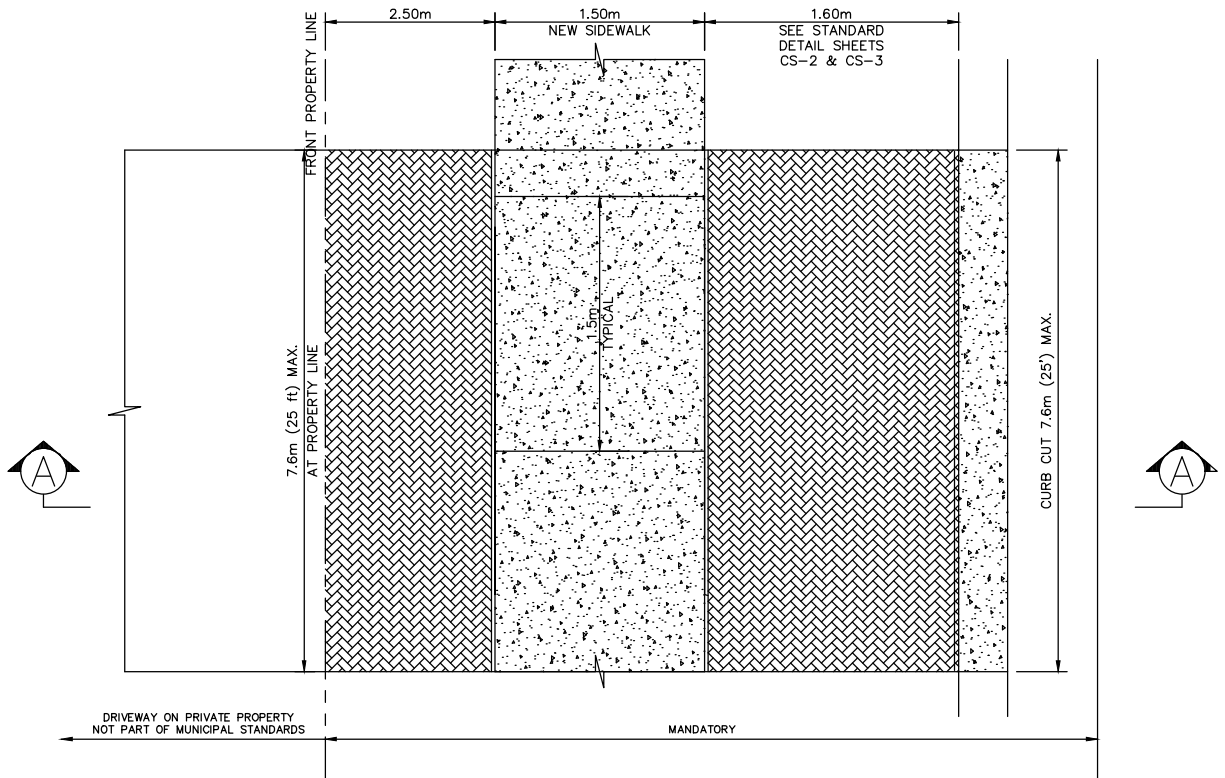

PLAN

Note: Taper included in the 7.6m (25') Curb Cut.

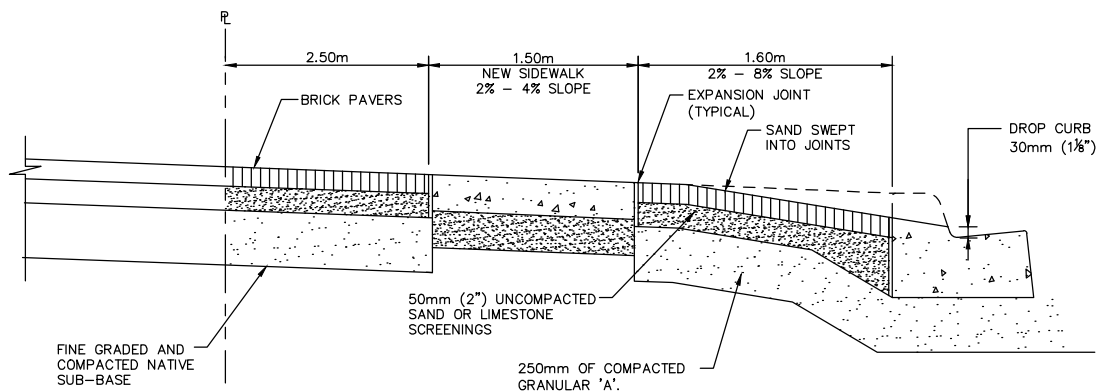

SECTION A-A

NOTES

1. BRICK PAVERS SHALL BE INSTALLED AS PER INSTRUCTIONS PROVIDED BY THE BRICK PAVER SUPPLIER.
2. APPROVAL BY A TOWN OF LAKESHORE ENGINEERING MANAGER IS REQUIRED IF APPROACH SLAB EXCEEDS 8% SLOPE.
3. RURAL AND SEMI-URBAN DRIVEWAY REQUIREMENTS ARE DETERMINED ON A CASE BY CASE SCENARIO. PLEASE CONTACT THE TOWN OF LAKESHORE PUBLIC WORKS DIVISION BEFORE PROCEEDING WITH HARD SURFACE OR CURB PLACEMENT WITHIN ROAD RIGHT-OF-WAY.



7	March 3, 2019
6	July 7, 2017
5	June 13, 2016
4	December 18, 2012
3	December 07, 2011
2	January 14, 2008
1	October 16, 2006
No.	Revision Date

Town of Lakeshore Development Manual

Figure D-5
URBAN RESIDENTIAL DRIVE
BRICK PAVERS WITH SIDEWALK

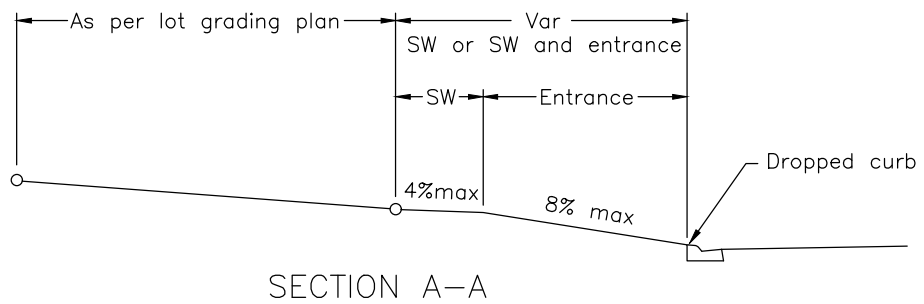
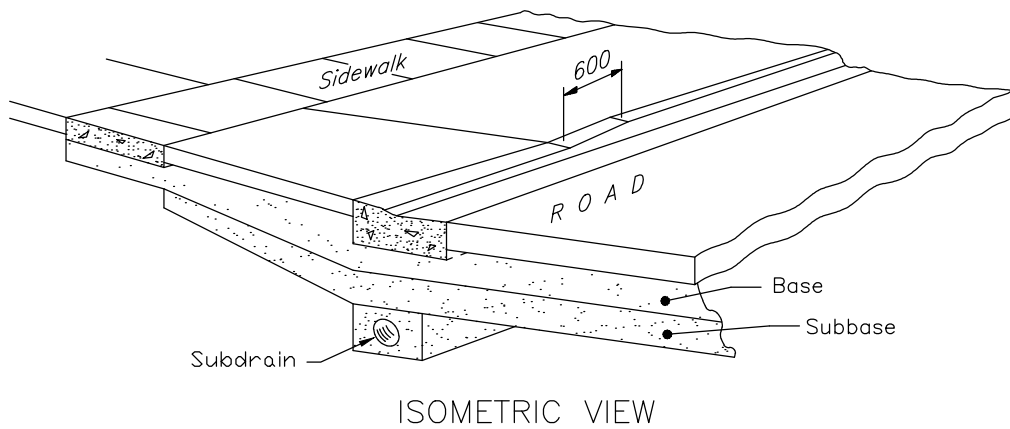
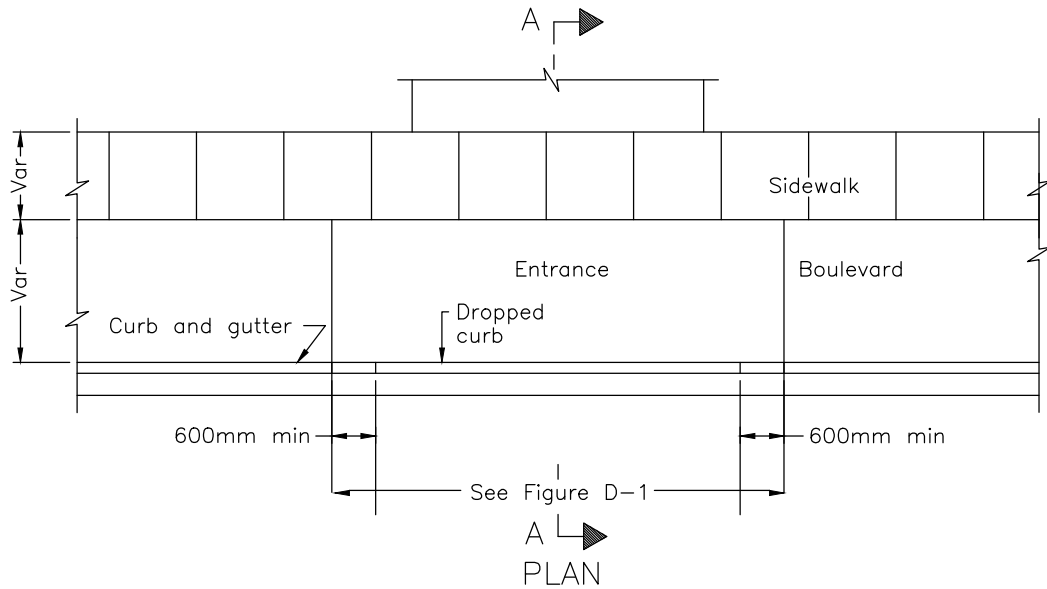

NOTES:

All dimensions are in millimetres unless otherwise shown.



No.	Revision Date
1	October 16, 2006
2	January 14, 2008
3	November 28, 2012

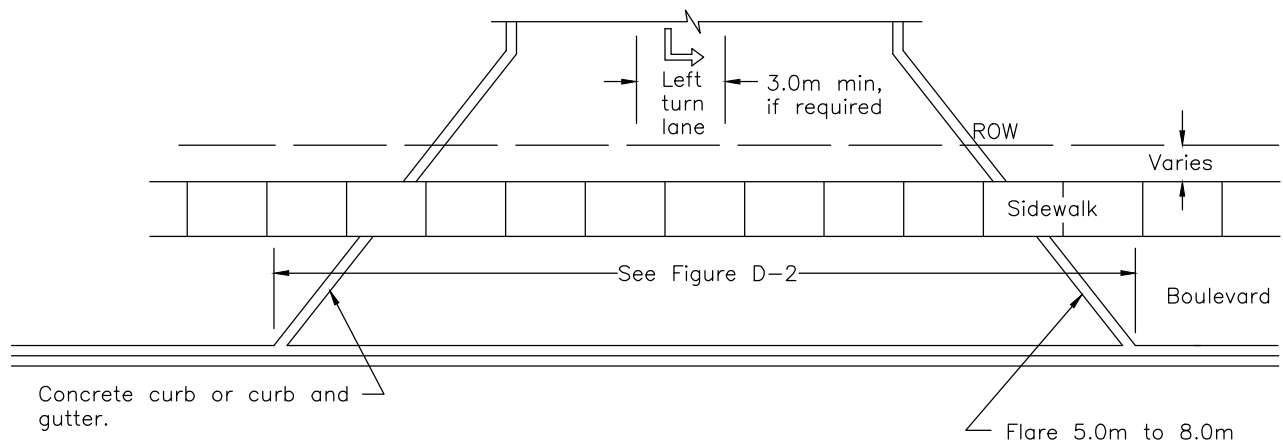

PLAN

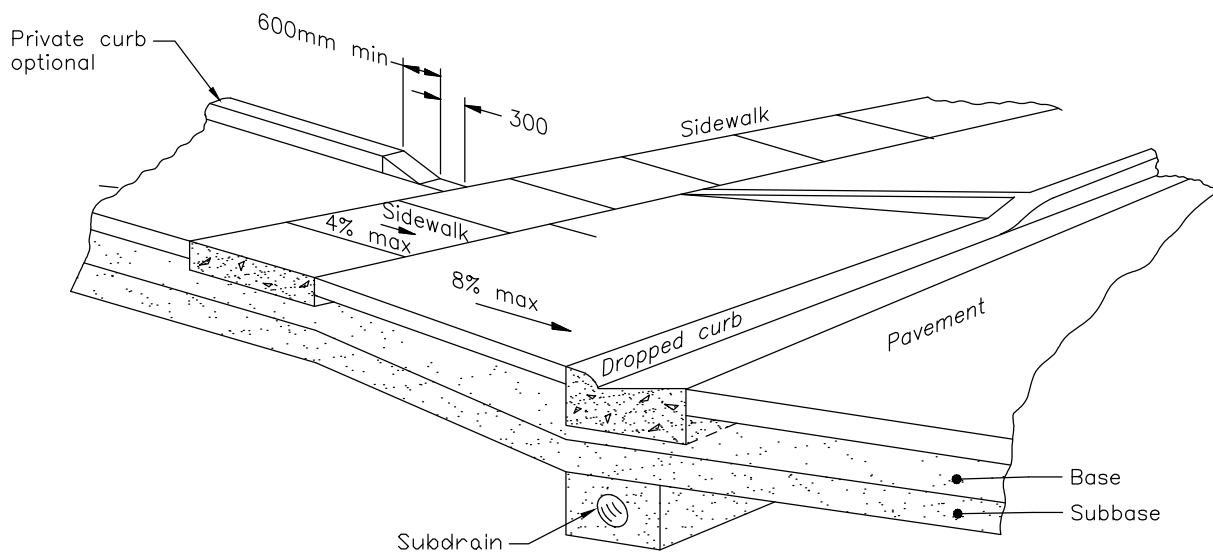

NOTES:

All dimensions are in millimetres unless otherwise shown.



No.	Revision Date
1	October 16, 2006
2	January 14, 2008
3	December 7, 2011

LUMINAIRE SPECIFICATIONS

CATALOGUE NO.: NXT-xxS/M-0-7-2ES/4AH

MANUFACTURER: LED ROADWAY
 IES DESIGNATION: TYPE II STANDARD;
 UNLESS OTHERWISE APPROVED

LIGHT SOURCE: LED
 LINE VOLTAGE: 120V

OPTIONS:
 • NEMA PHOTOCELL RECEPTACLE
 • PHOTOCELL
 PAINT: BLACK
 (TO BE CONFIRMED)

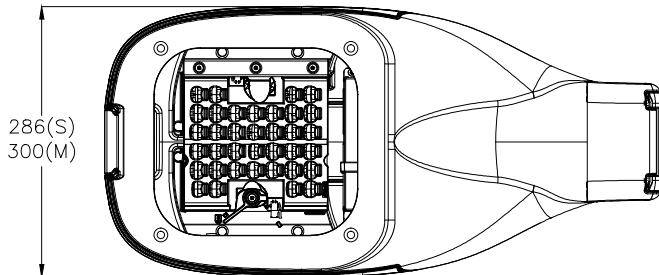
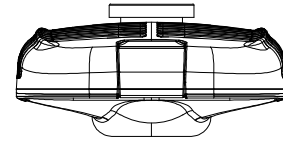
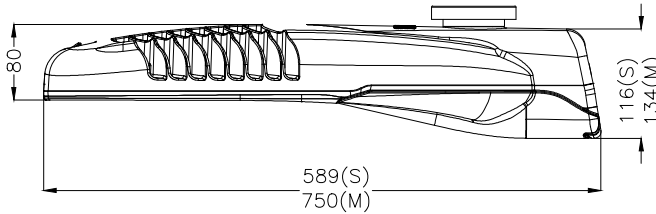
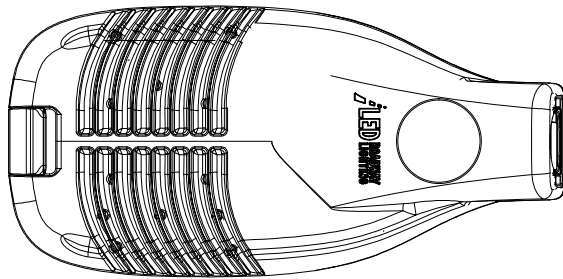

3	JULY 20, 2016
2	FEBRUARY 28, 2014
1	DECEMBER 5, 2013
No.	Revision Date

LUMINAIRE SPECIFICATIONS

CATALOGUE NO.: K118R-xxAR-III-100(SSL)

MANUFACTURER: KING LUMINAIRE, WASHINGTON

POLE ADAPTOR: K14

OPTICAL SYSTEM: REFRACTIVE ARRAY ACRYLIC RIPPLED TYPE III (UNLESS OTHERWISE NOTED)

IES LTG. CLASS.: 100W (UNLESS OTHERWISE NOTED)

INPUT WATTS: SOLID STATE LIGHTING

SERIES: 1063

CCT: 4000K

LINE VOLTAGE: 120-277V

PAINT: TEXTURED BLACK (TO BE CONFIRMED)

OPTIONS:

- TWISTLOCK RECEPTACLE
- PHOTO CELL
- SPUN ALUMINUM TOP
- VENTED FINIAL

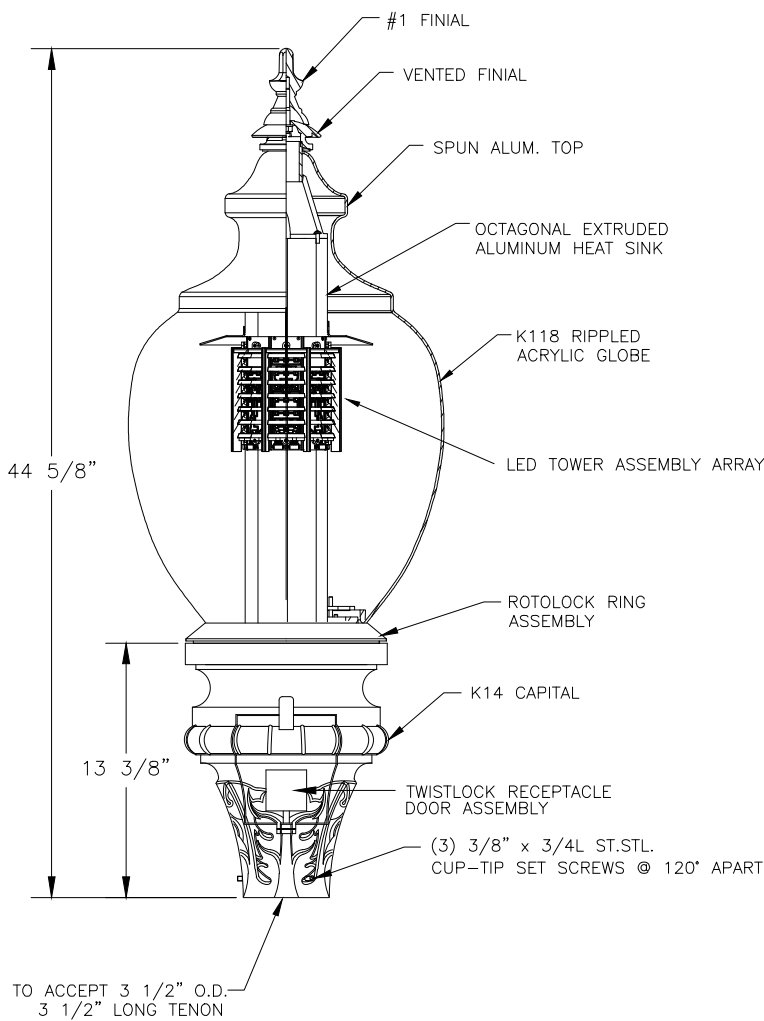

3	JULY 20, 2016
2	FEBRUARY 28, 2014
1	DECEMBER 5, 2013
No.	Revision Date

FIGURE E-02

D □ CORAT □ □ ACR □ LC STR □ □ T L □ □ □ T □ IN □
L □ D SO □ RC □

LUMINAIRE SPECIFICATIONS

CATALOGUE NO.: AWDE2-P50-40K

MANUFACTURER: HOLOPHANE, WASHINGTON POSTLITE II

OPTICAL SYSTEM: CLEAR PRISMATIC ACRYLIC
 IES LTG. CLASS: TYPE III
 (UNLESS OTHERWISE APPROVED)

INPUT WATTS: 100W (UNLESS OTHERWISE APPROVED)
 SOLID STATE LIGHTING

SERIES: P50
 CCT: 4000K
 LINE VOLTAGE: AUTO SENSING 120V
 PAINT: TEXTURED BLACK
 (TO BE CONFIRMED)

OPTIONS:

- TWISTLOCK RECEPTACLE
- DTL TWISTLOCK PHOTO CELL
- TOP REFLECTOR & CAP
- STANDARD FINIAL

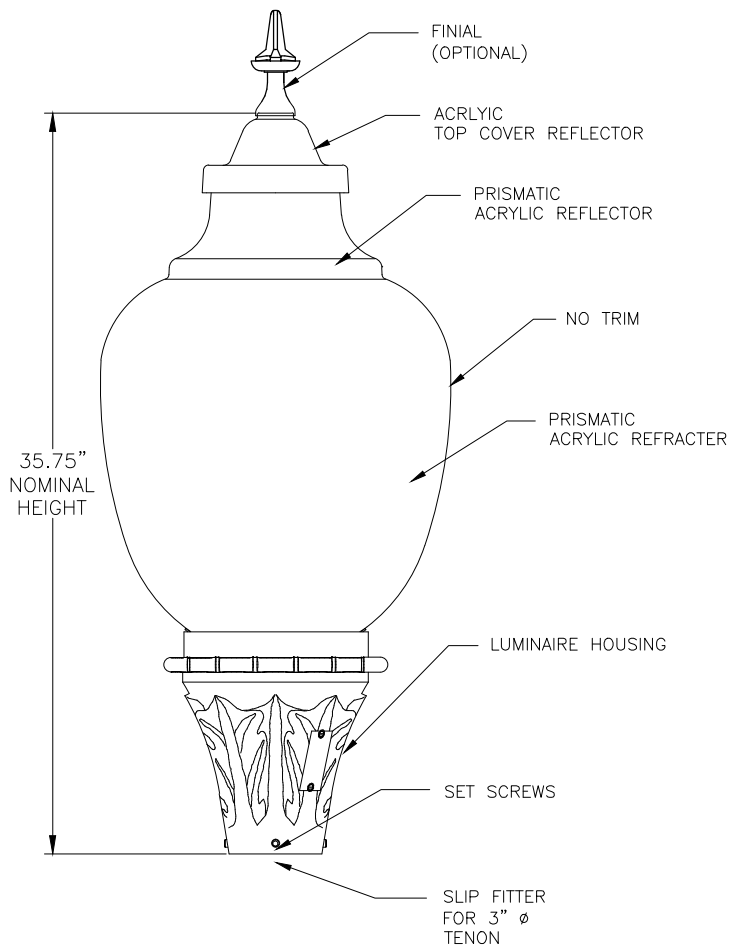

3	JULY 20, 2016
2	FEBRUARY 28, 2014
1	DECEMBER 5, 2013
No.	Revision Date

FIGURE E-03

DECORATIVE ACRYLIC STREET LIGHTING
 LIGHT SOURCE

LUMINAIRE SPECIFICATIONS

CATALOGUE NO.: K118-xxPR-III-100(SSL)

MANUFACTURER: KING LUMINAIRE, WASHINGTON
 POLE ADAPTOR: K14
 OPTICAL SYSTEM: REFRACTIVE ARRAY POLYCARBONATE RIPPLED
 IES LTG. CLASS.: TYPE III (UNLESS OTHERWISE APPROVED)
 INPUT WATTS: 100W (UNLESS OTHERWISE NOTED)
 SOLID STATE LIGHTING

SERIES: 1063
 CCT: 4000K
 LINE VOLTAGE: 120-277V
 PAINT: TEXTURED BLACK
 (TO BE CONFIRMED)

- OPTIONS:
- TWISTLOCK RECEPTACLE
 - PHOTO CELL
 - SPUN SPUN TOP
 - POLE CAPITAL

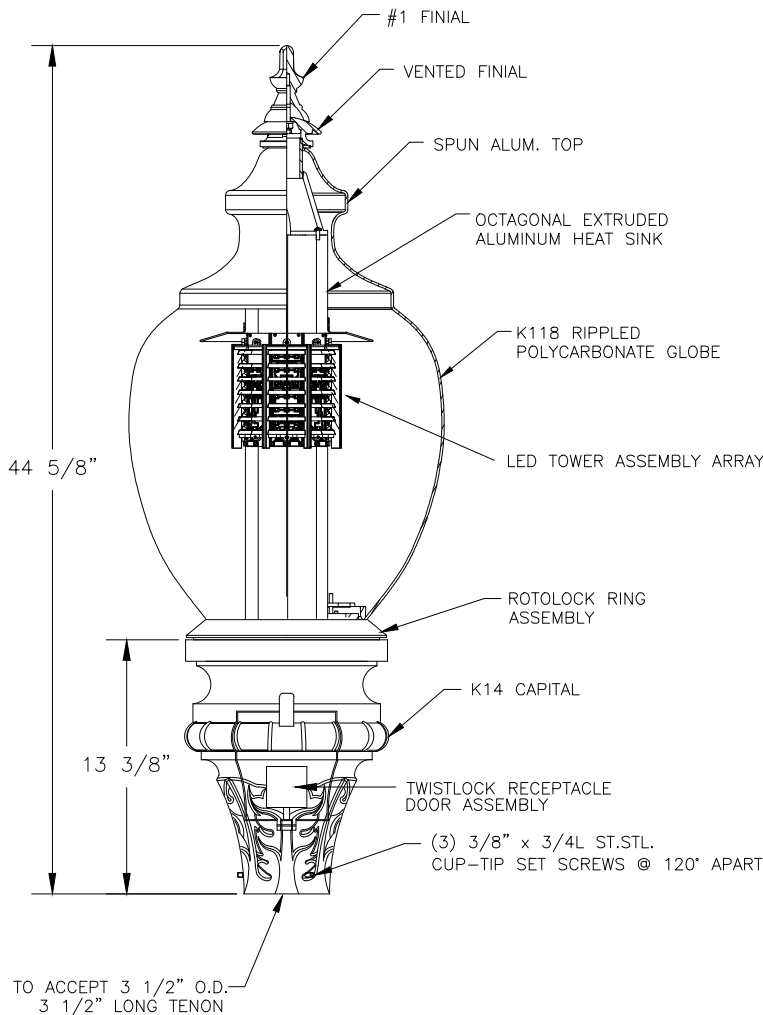

3	JULY 20, 2016
2	FEBRUARY 26, 2014
1	DECEMBER 5, 2013
No.	Revision Date

FIGURE E-04

D □ CORAT □ □ □ OL □ CAR □ ONAT □ STR □ OT L □ □ T □ IN □
 L □ D SO □ RC □

LUMINAIRE SPECIFICATIONS

CATALOGUE NO.: WAUE2-P50-40K

MANUFACTURER: HOLOPHANE, WASHINGTON POSTLITE

OPTICAL SYSTEM: CLEAR PRISMATIC GLASS
 IES LTG. CLASS: TYPE III
 (UNLESS OTHER APPROVED)

INPUT WATTS: 100W (UNLESS OTHER APPROVED)
 SOLID STATE LIGHTING

SERIES: P50
 CCT: 4000K

LINE VOLTAGE: AUTO SENSING 120V
 PAINT: TEXTURED BLACK
 (TO BE CONFIRMED)

OPTIONS:

- TWISTLOCK RECEPTACLE
- DTL TWISTLOCK PHOTO CELL
- SPIKE ALUMINUM FINIAL
- SHOREWOOD STYLE COVER

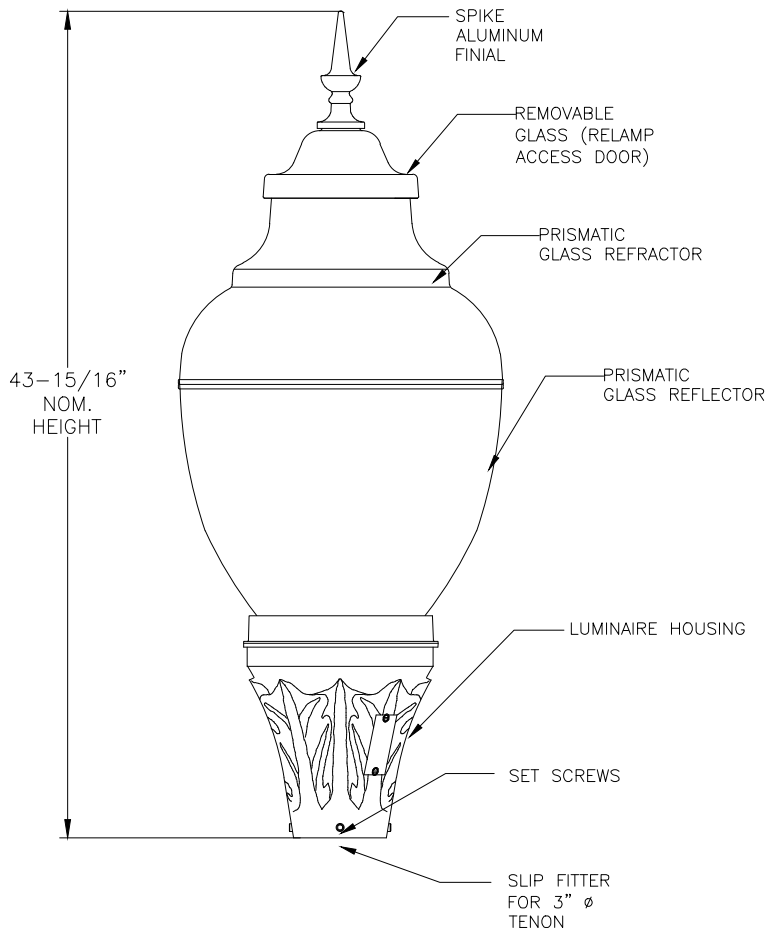

3	JULY 20, 2016
2	FEBRUARY 28, 2014
1	DECEMBER 5, 2013
No.	Revision Date

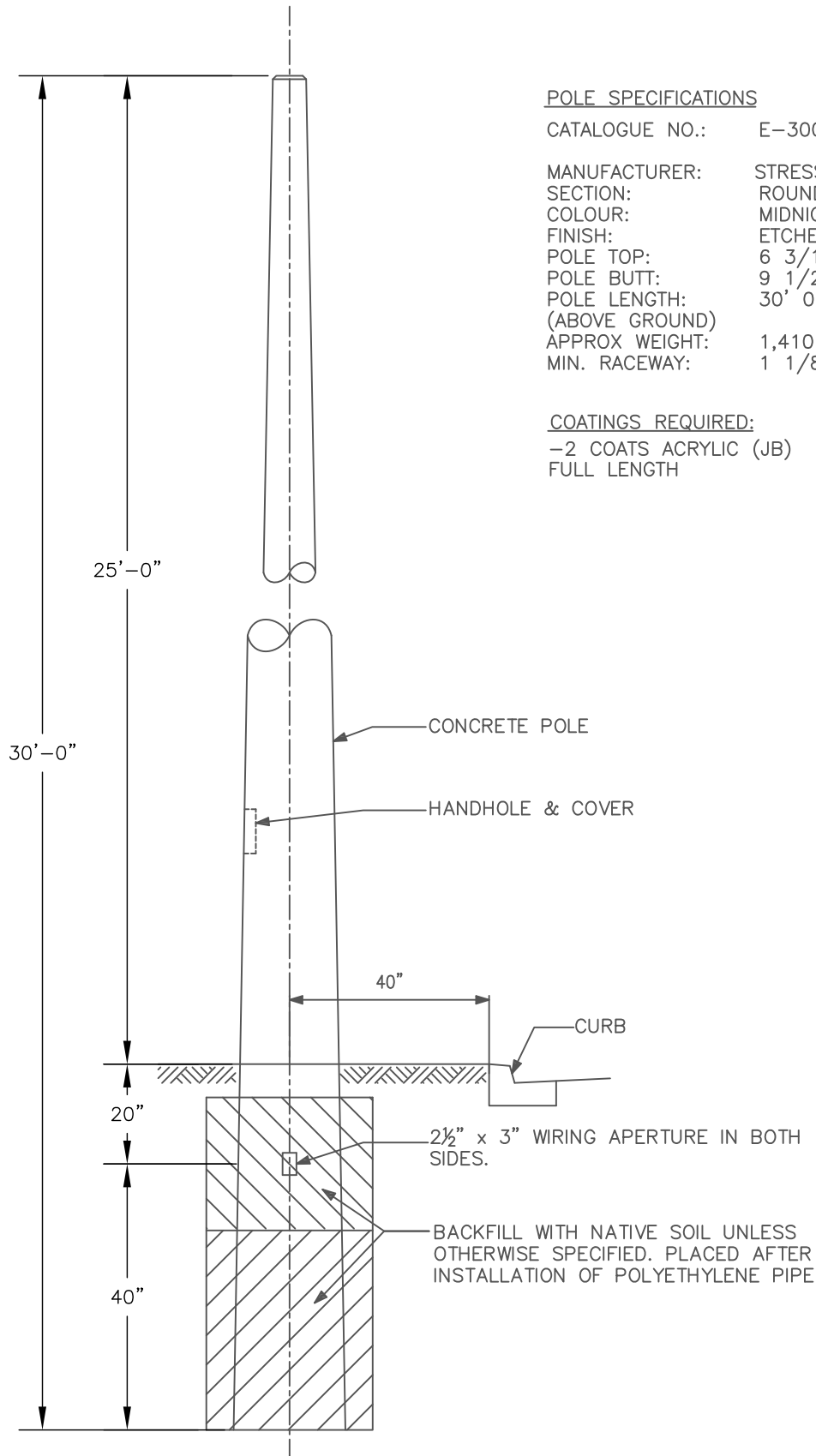

POLE SPECIFICATIONS

CATALOGUE NO.: E-300-APR-G-M00

MANUFACTURER: STRESSCRETE

SECTION: ROUND

COLOUR: MIDNIGHT LACE

FINISH: ETCHED

POLE TOP: 6 3/16" FL/FL

POLE BUTT: 9 1/2" ϕ

POLE LENGTH: 30' 0"

(ABOVE GROUND)

APPROX WEIGHT: 1,410 lbs

MIN. RACEWAY: 1 1/8" ϕ

COATINGS REQUIRED:

-2 COATS ACRYLIC (JB)
FULL LENGTH

No.	Revision Date
3	FEBRUARY 13, 2019
2	FEBRUARY 28, 2014
1	DECEMBER 5, 2013

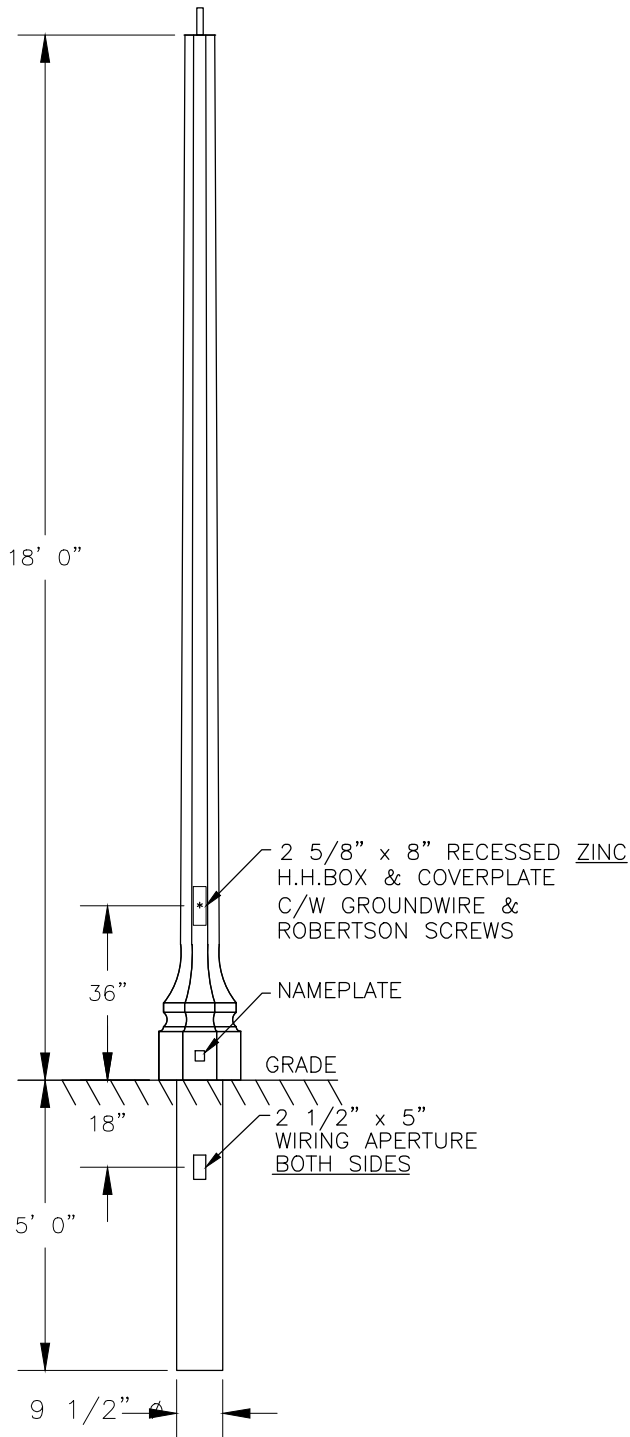

POLE SPECIFICATIONS

CATALOGUE NO.: KBH18-E10
 DB 140-35/40
 MANUFACTURER: STRESSCRETE
 SECTION: OCTAGONAL
 COLOUR: MIDNIGHT LACE
 FINISH: ETCHED
 POLE TOP: 6 3/16" FL/FL
 POLE BUTT: 9 1/2" ø
 POLE LENGTH: 18' 0"
 (ABOVE GROUND)
 APPROX WEIGHT: 1,410 lbs
 MIN. RACEWAY: 1 1/8" ø

COATINGS REQUIRED:

-2 COATS ACRYLIC (JB)
 FULL LENGTH

POLE SPECIFICATIONS

CATALOGUE NO.: KBH18-E11
 DB 140-35/40
 MANUFACTURER: STRESSCRETE
 SECTION: OCTAGONAL
 COLOUR: ECLIPSE
 FINISH: ETCHED
 POLE TOP: 6 3/16" FL/FL
 POLE BUTT: 9 1/2" ø
 POLE LENGTH: 18' 0"
 (ABOVE GROUND)
 APPROX WEIGHT: 1,410 lbs
 MIN. RACEWAY: 1 1/8" ø

COATINGS REQUIRED:

-2 COATS ACRYLIC (JB)
 FULL LENGTH

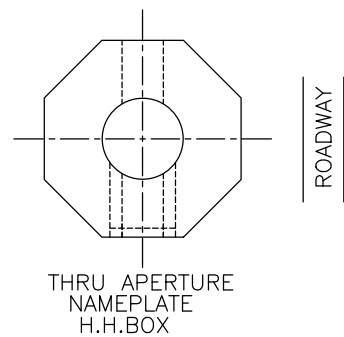

TOP VIEW



No.	Revision Date
3	JULY 20, 2016
2	FEBRUARY 28, 2014
1	DECEMBER 5, 2013

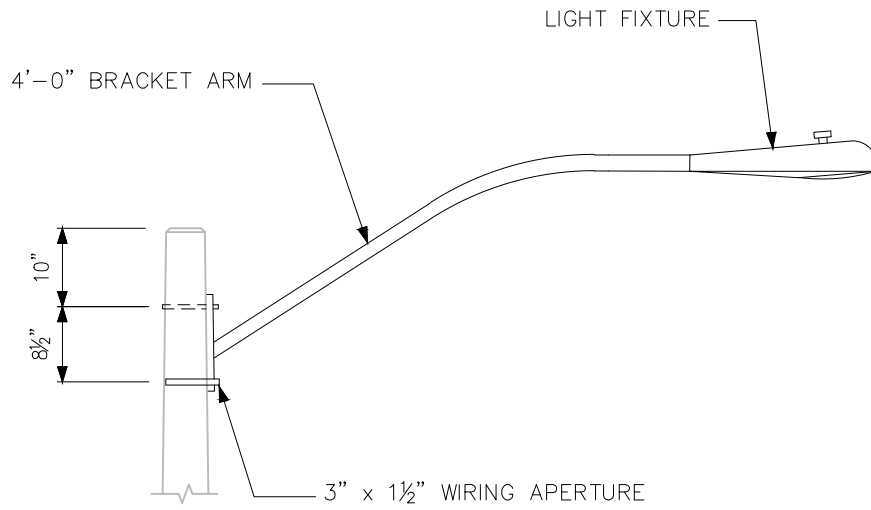

2	FEBRUARY 28, 2014
1	DECEMBER 5, 2013
No.	Revision Date

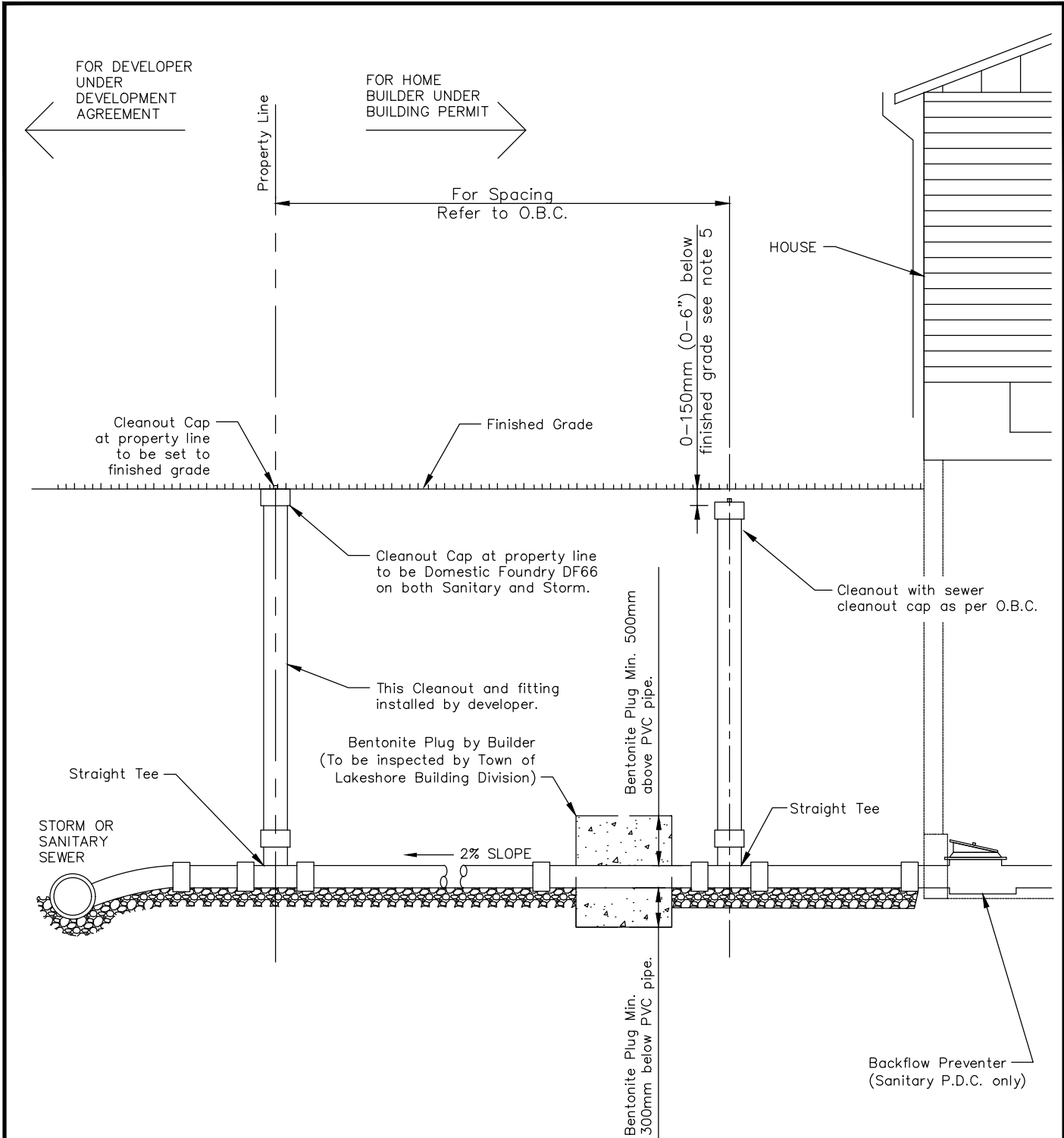

NOTE

1. From main sewers, storm to be 150mm (6"). Sanitary to be 125mm (5"). Sanitary to be 150mm (6") for all long side sanitary laterals with a wye to a double cleanout. All pipe to be PVC DR-28 pipe.
2. All materials to be in compliance with O.B.C. and installed as per manufacturers recommendations.
3. Storm invert at property line to be minimum of 1.2m down from finished grade.
4. Sanitary invert at property line to be minimum of 2.4m down from finished grade.
5. All cleanouts to be visible for inspection. Do NOT bury.
6. Backflow Preventer on Sanitary P.D.C. only.



No.	Revision Date
5	March 3, 2019
4	July 7, 2017
3	January 27, 2014
2	January 14, 2008
1	October 16, 2006

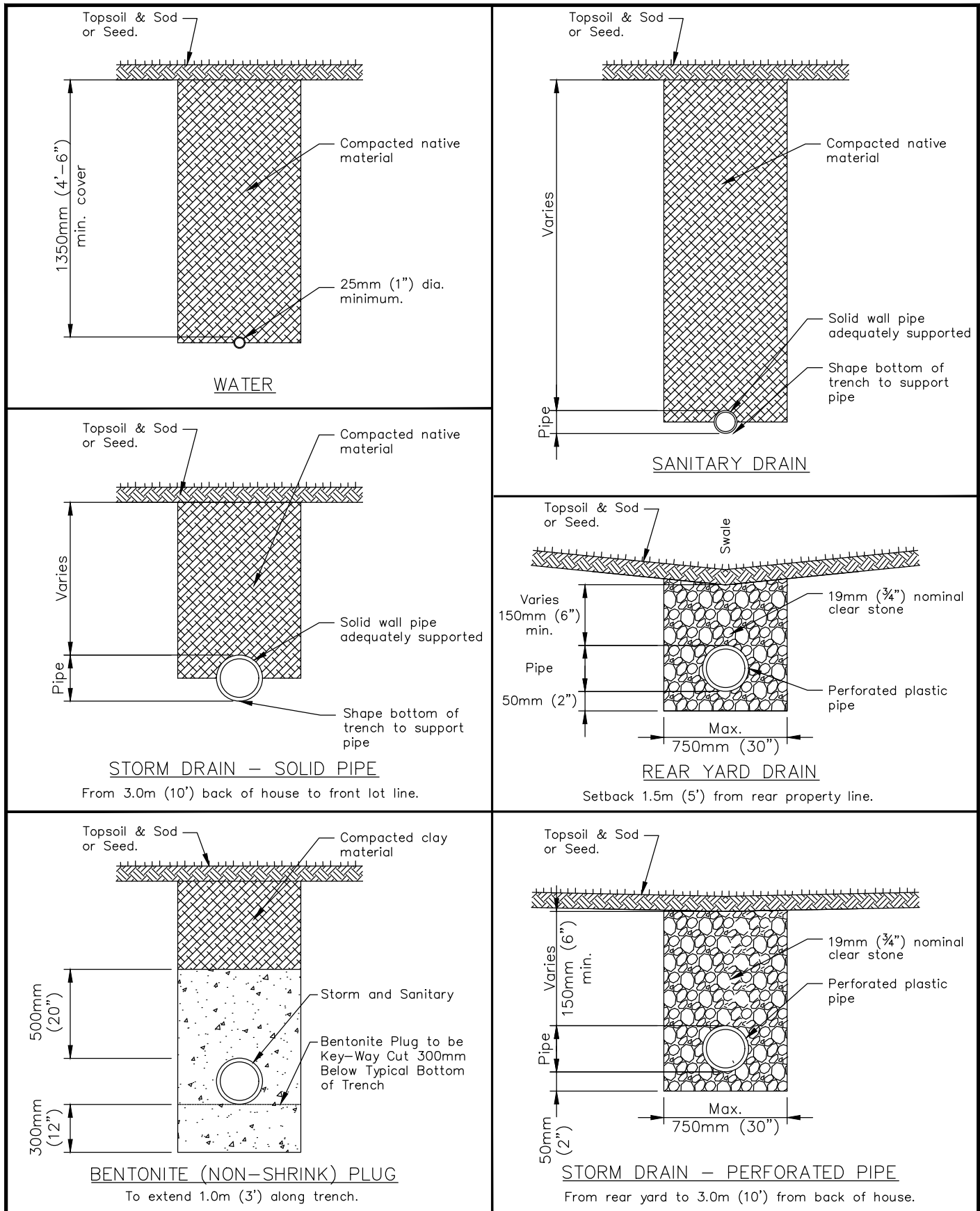

No.	Revision Date
1	October 16, 2006
2	January 14, 2008
3	January 27, 2014
4	March 3, 2019

2-150mm dia. inlets.
Hole location to suit
rear yard drain.

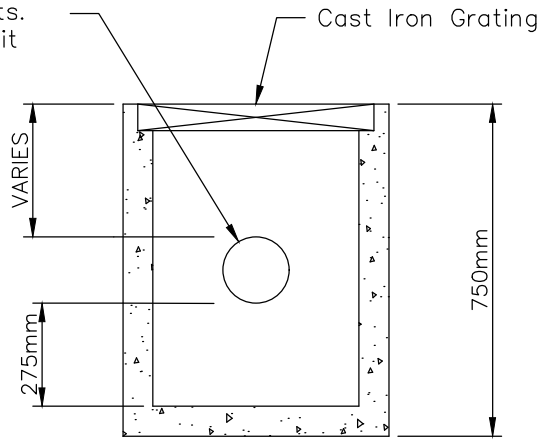
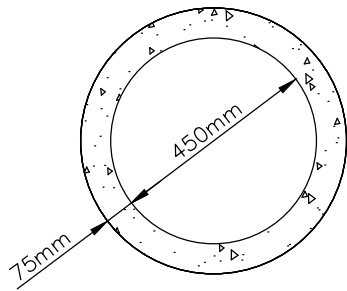

NOTE:

1. Concrete to be 30MPa, air entrained 6% ± 1 ½%.
2. Alternate rear yard catch basins may be acceptable. Check with Chief Building Official.

REAR YARD CATCH BASIN
(CONCRETE)

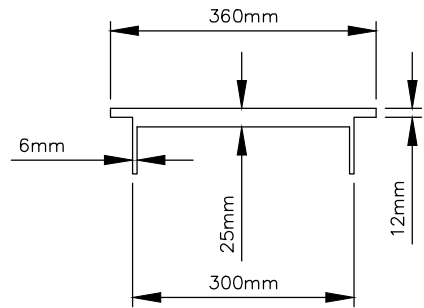
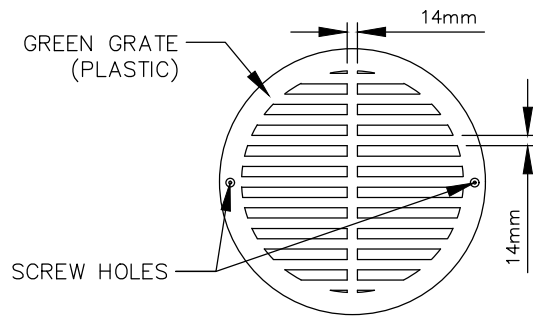
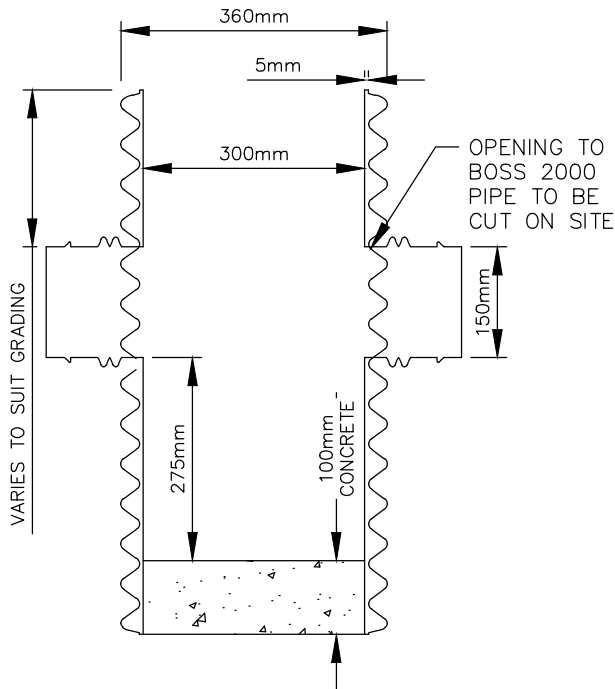

REAR YARD CATCH BASIN
(PLASTIC)



No.	Revision Date
1	October 16, 2006
2	January 14, 2008

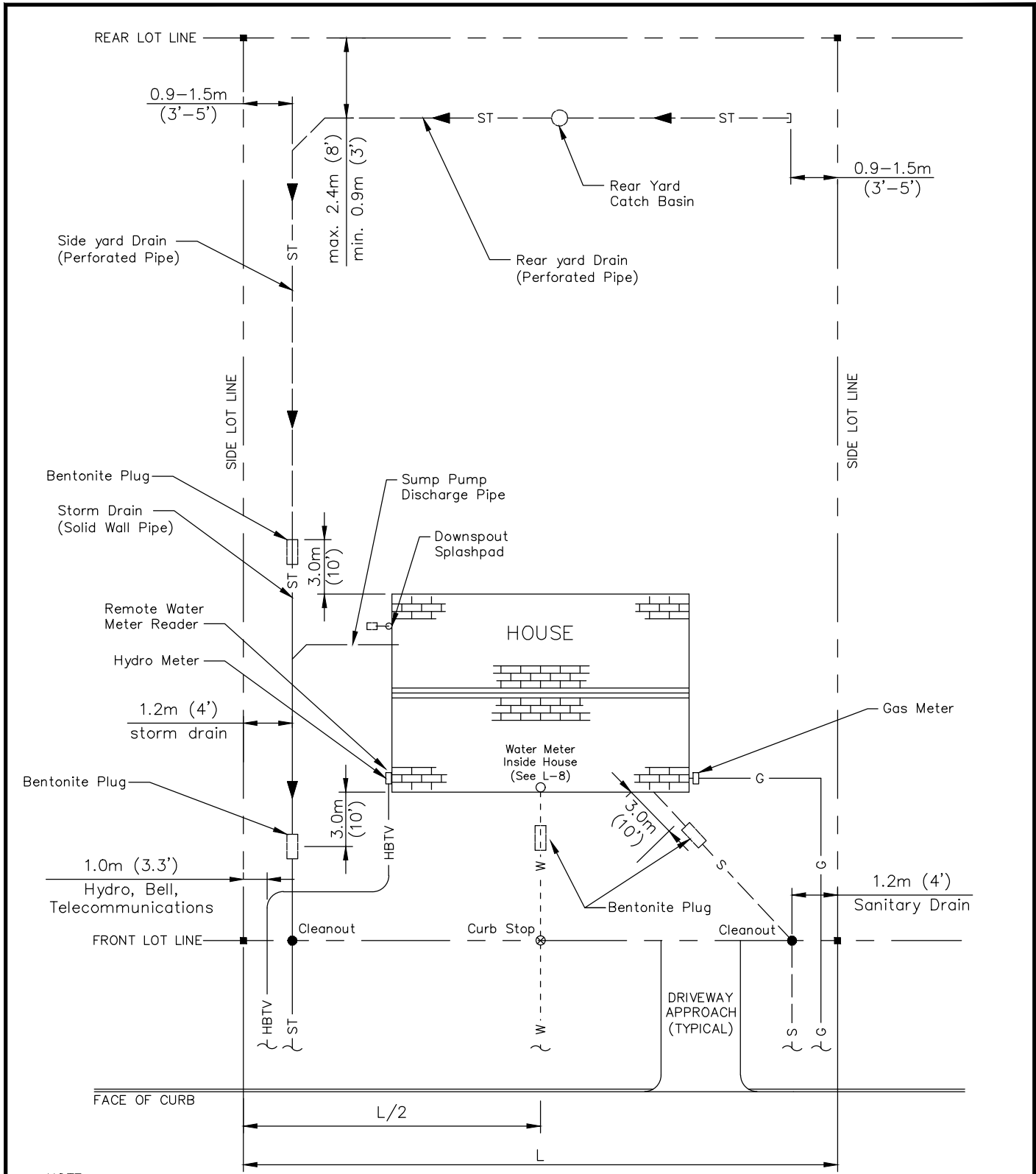

- NOTE**
1. Offsets shown are typical, they may vary based on servicing drawings.
 2. See O.B.C. for cleanout spacing.
 3. Rear yard catch basin location to be approved by Town.
 4. Services to be position outside of proposed driveways if possible.



No.	Revision Date
4	April 8, 2019
3	July 7, 2017
2	January 14, 2008
1	October 16, 2006

Figure L-4
LOT SERVICE LOCATIONS

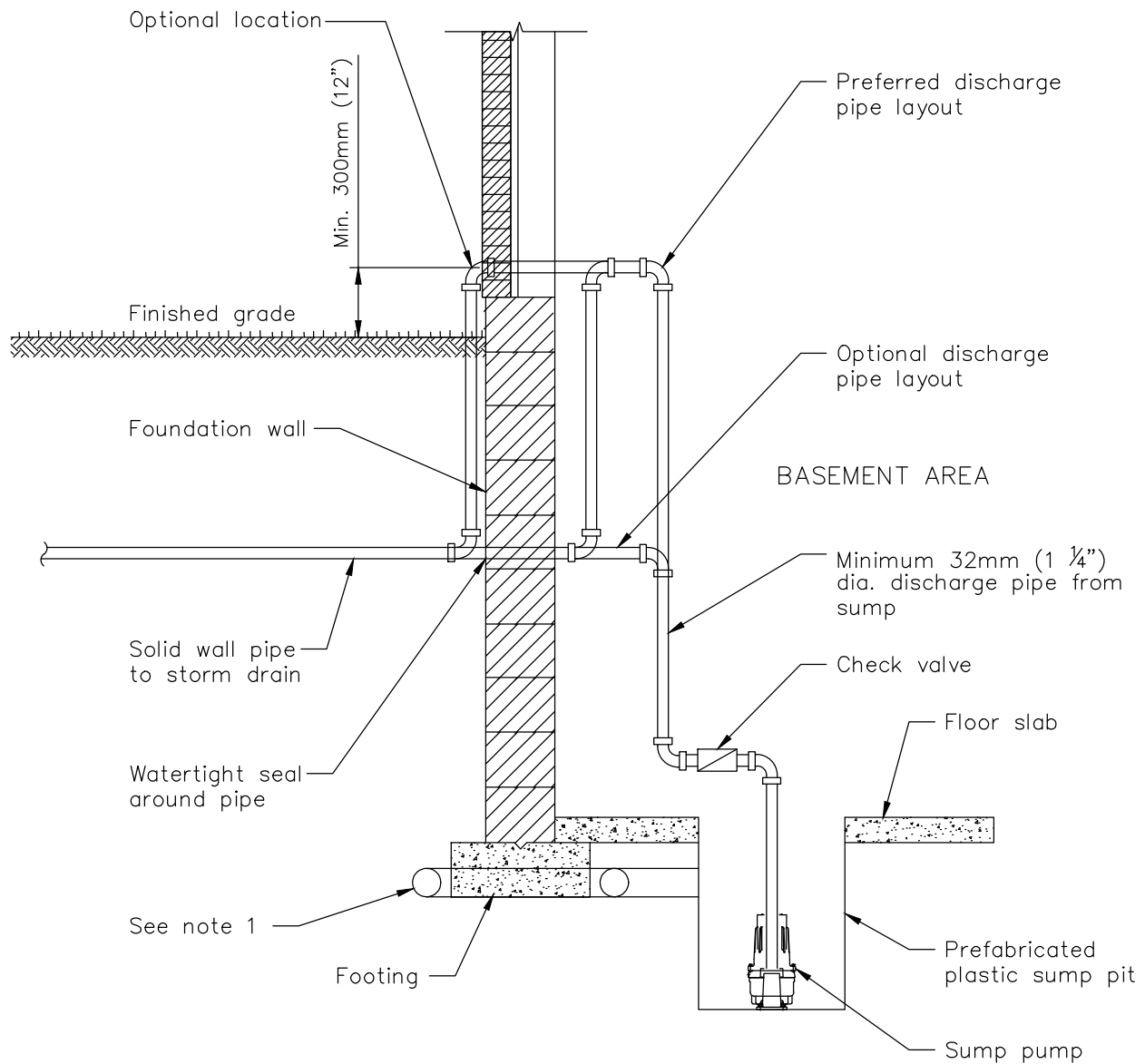

NOTE:

1. Perforated footing drain with cross-overs connected to sump pit.
2. Support piping to wall.

Drawing is for illustration purpose only.

NOTE:

THIS DETAIL APPLIES IF GROUND WATER ELEVATION IS BELOW THE FOOTING. IF NOT, PROVIDE AN ALTERNATE DESIGN PREPARED BY A PROFESSIONAL ENGINEER



No.	Revison Date
1	October 16, 2006
2	January 14, 2008

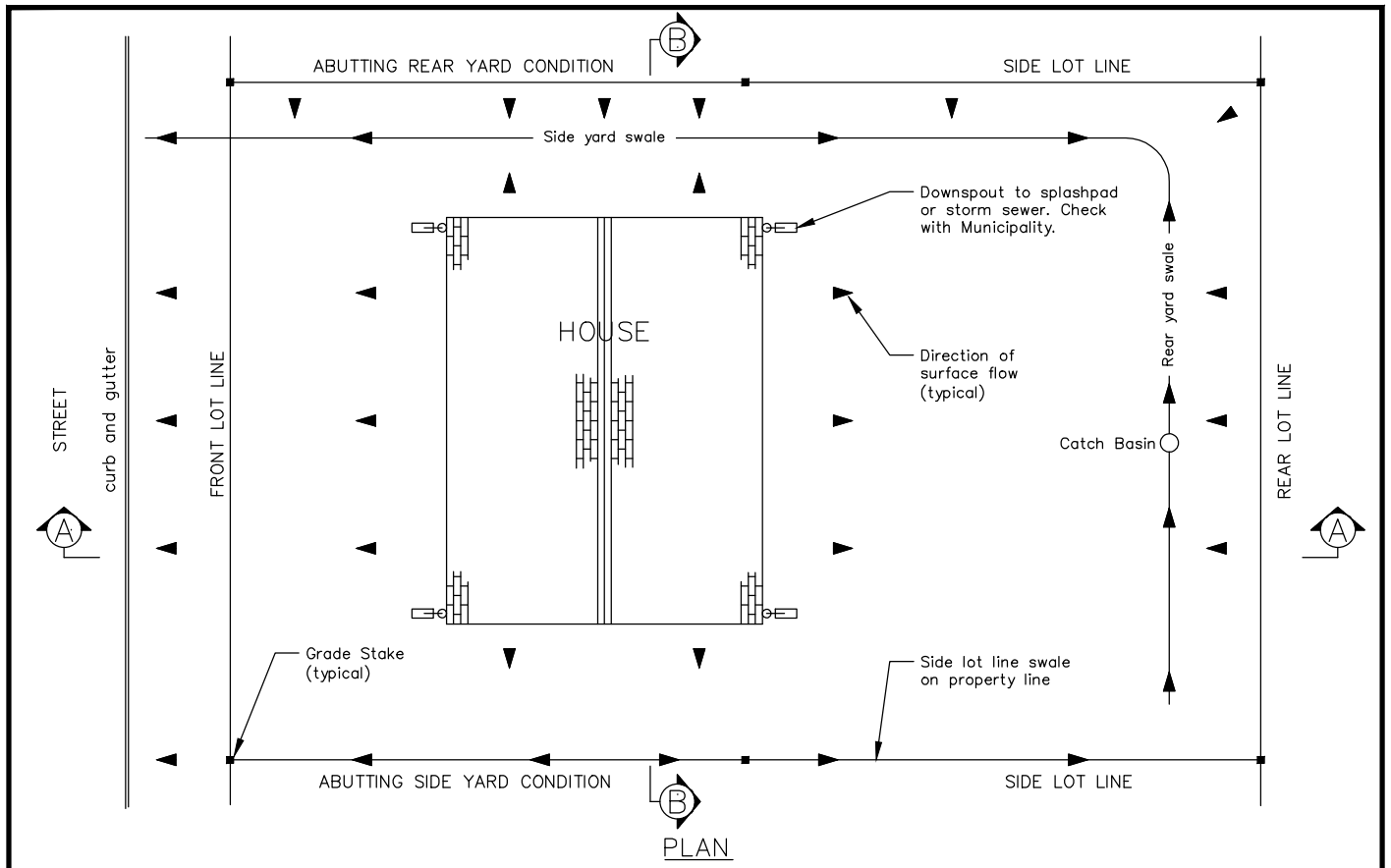

PLAN

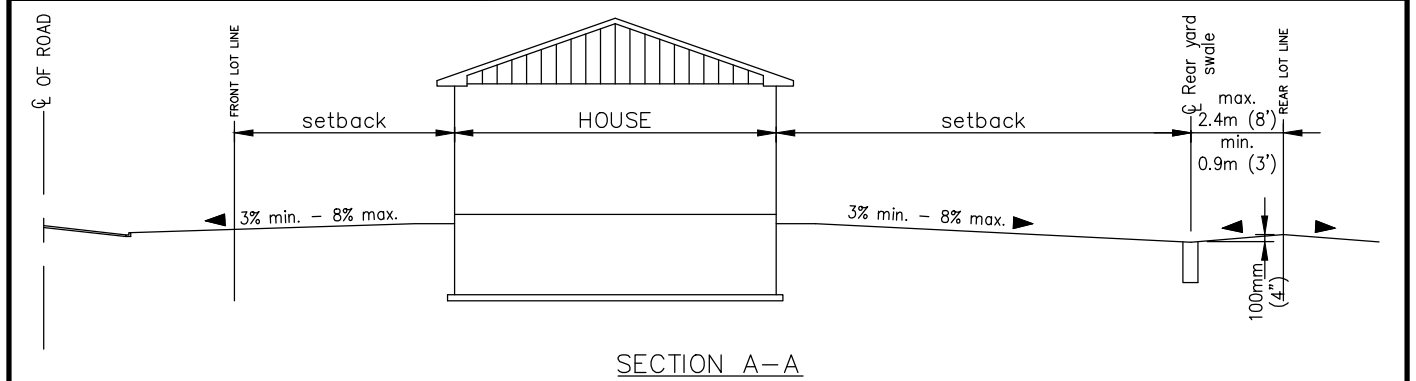

SECTION A-A

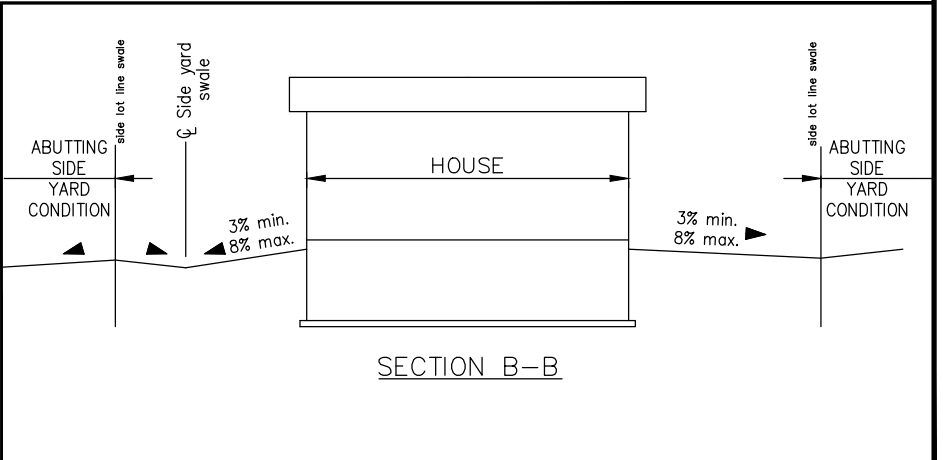
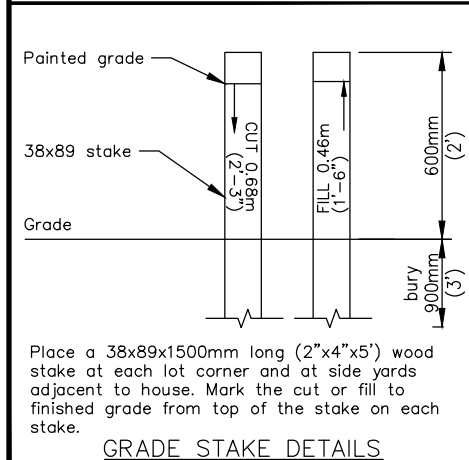

SECTION B-B



No.	Revision Date
2	January 14, 2008
1	October 16, 2006

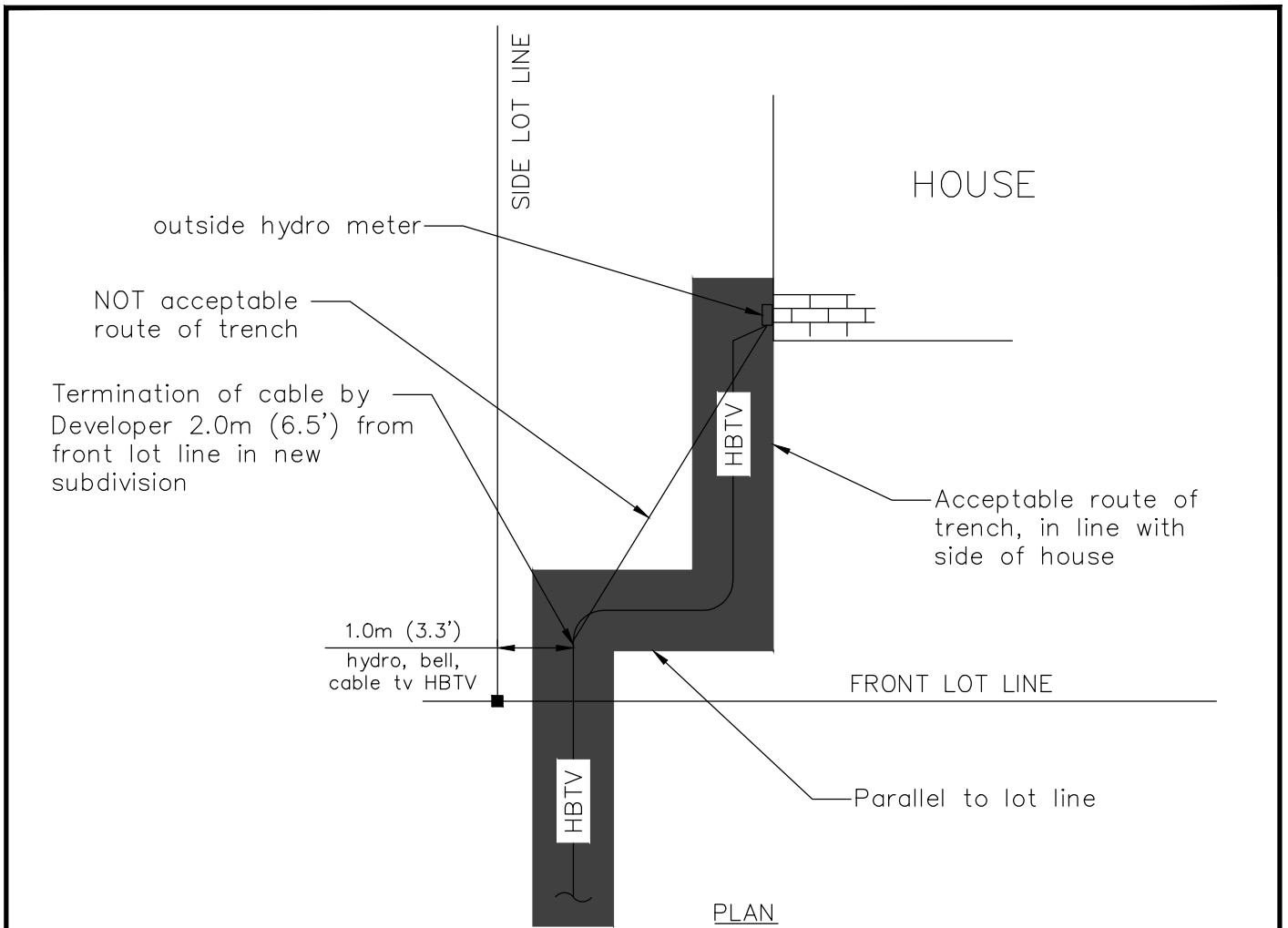

NOTE

1. Obtain approval from ELK/Hydro One office for meter location on house.
2. Do not bury Big'O' conduit until after hydro cable installation and after inspection by ELK/Hydro One.

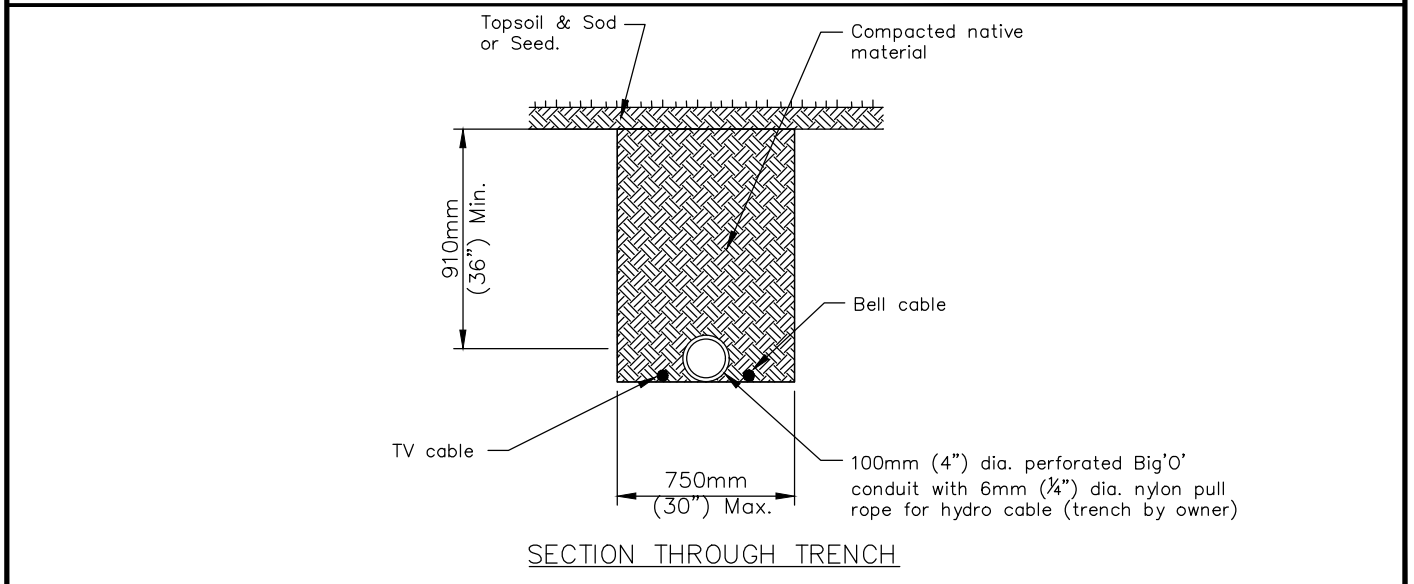

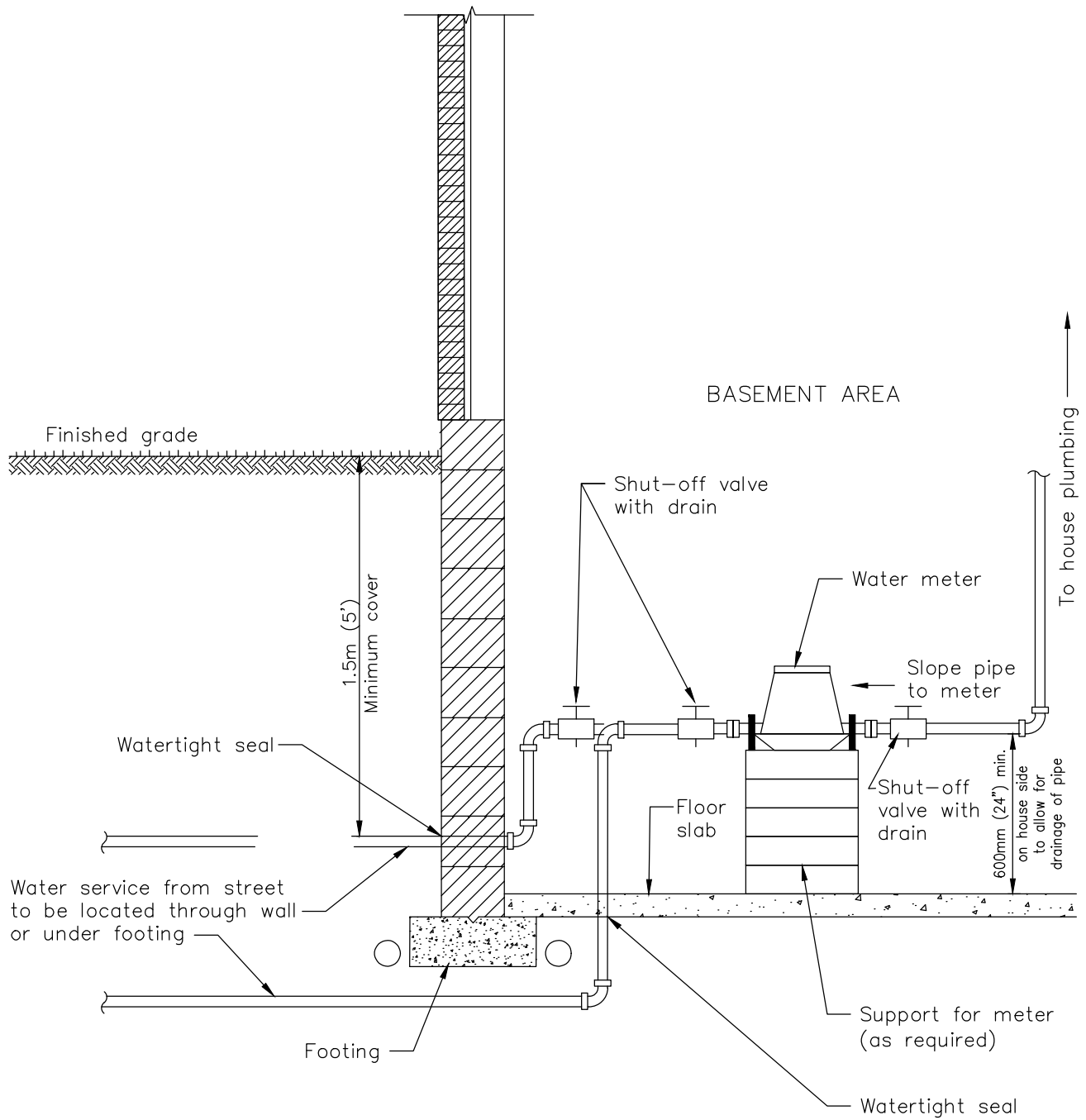

NOTE:

1. Secure meter and piping to structure.



No.	Revision Date
3	April 14, 2009
2	January 14, 2008
1	October 16, 2006

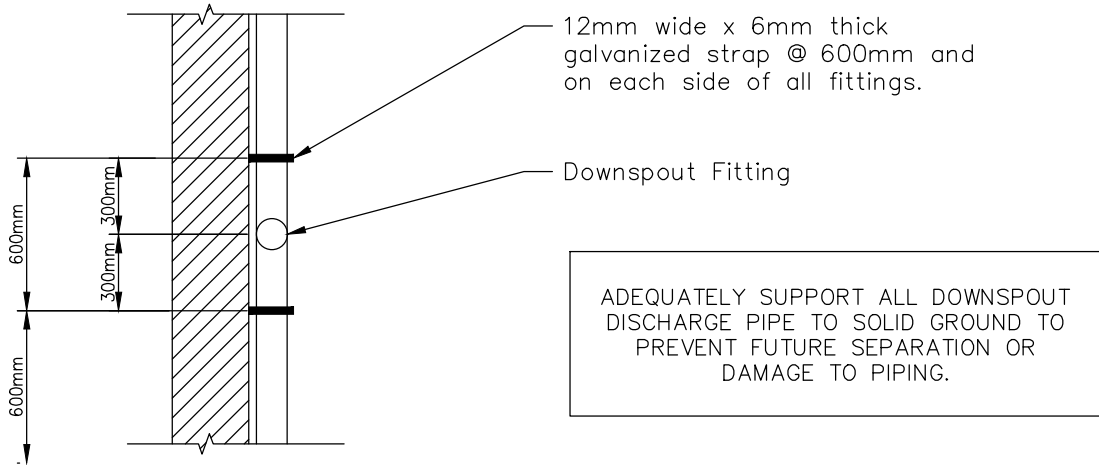

PLAN

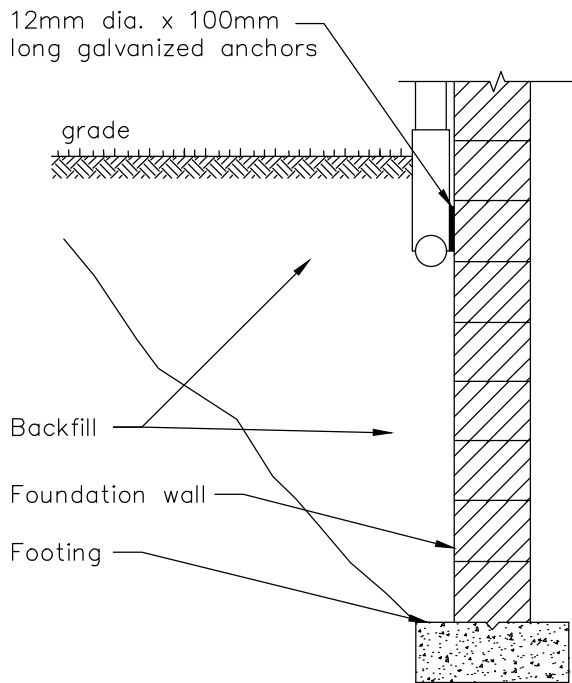

WALL SECTION ALTERNATIVE NO. 1

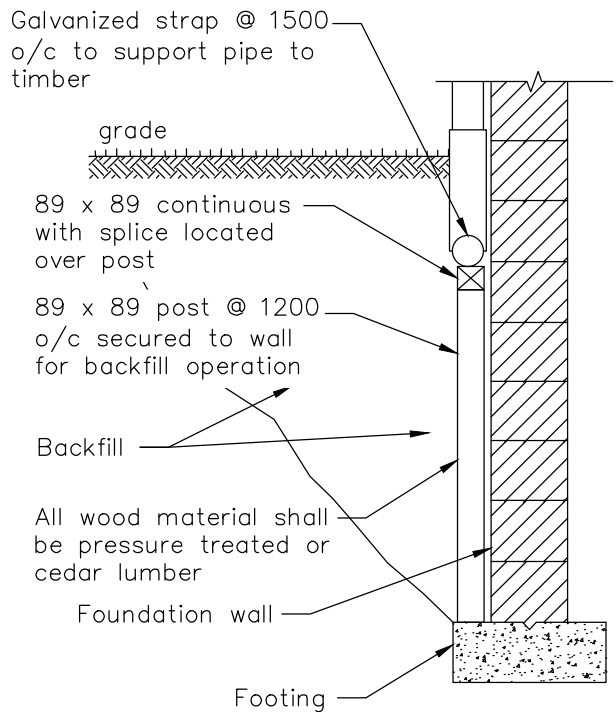

WALL SECTION ALTERNATIVE NO. 2
(PREFERRED)



No.	2	January 14, 2008
	1	October 16, 2006
		Revision Date

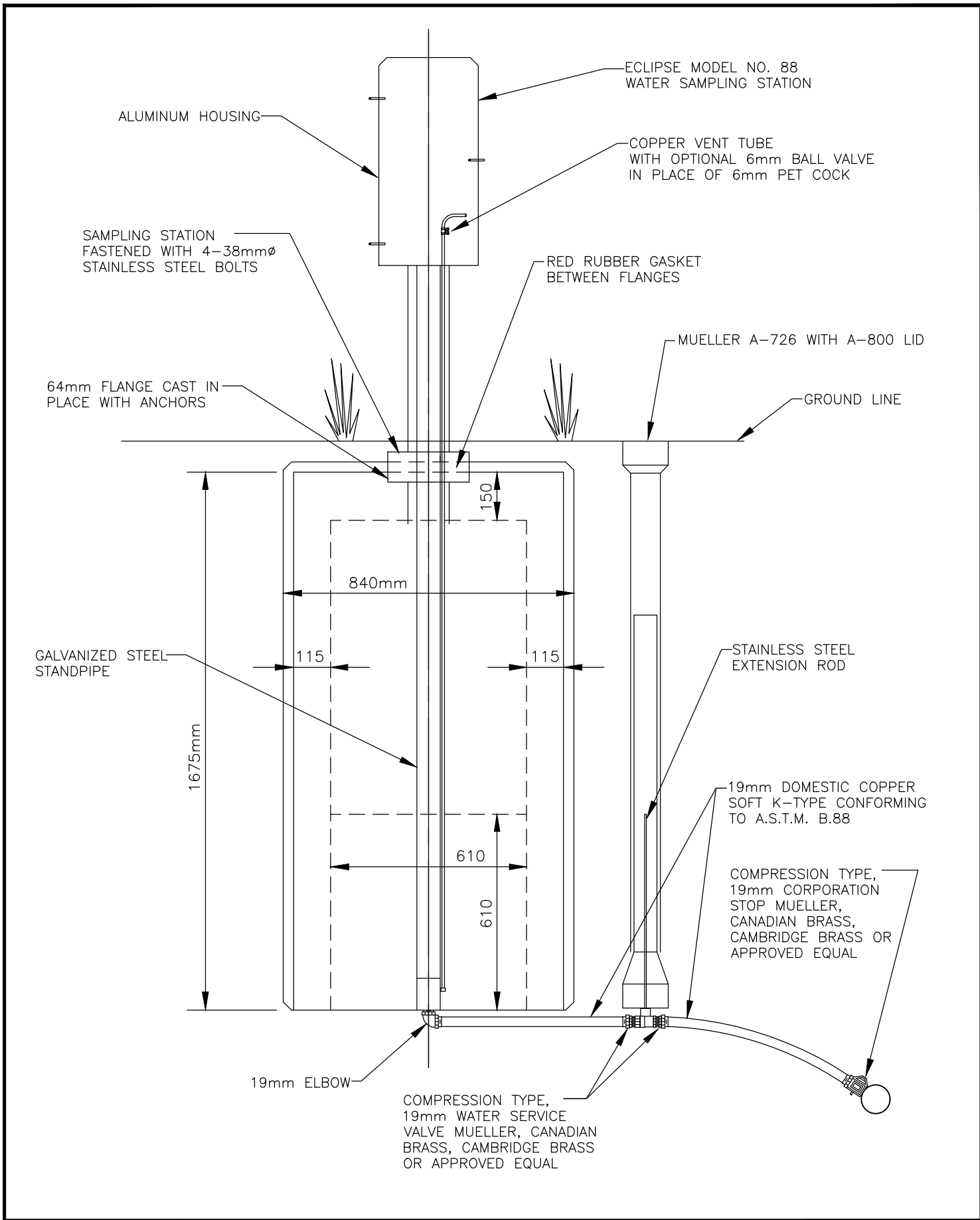

1	October 16, 2006
No.	Revision Date

Figure L-10
WATER SAMPLING STATION

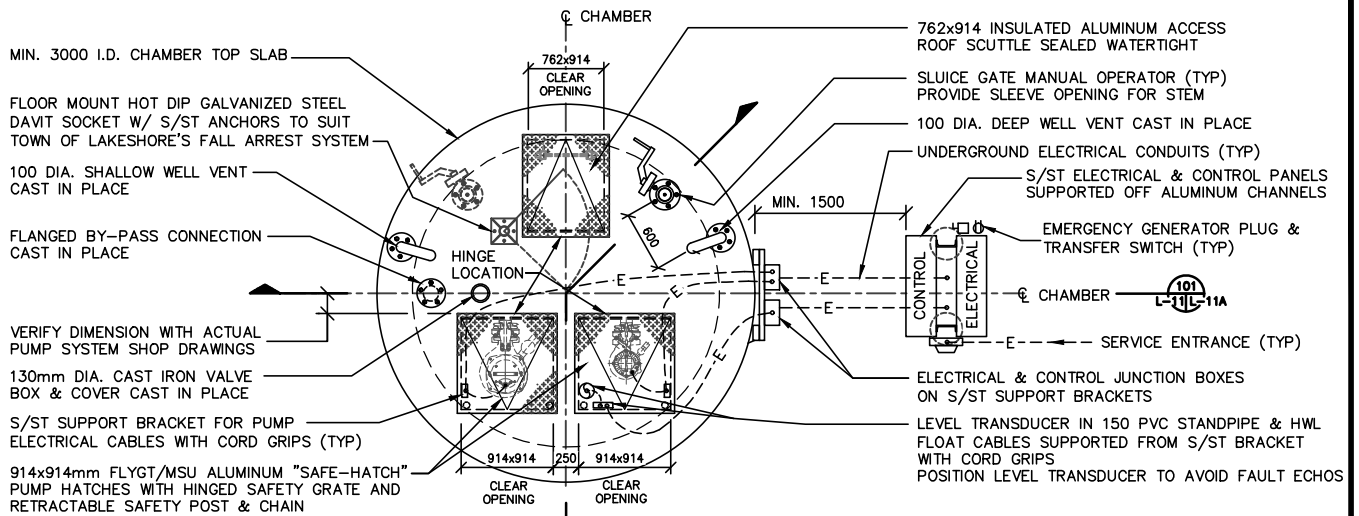

TYPICAL TOP PLAN

N.T.S.

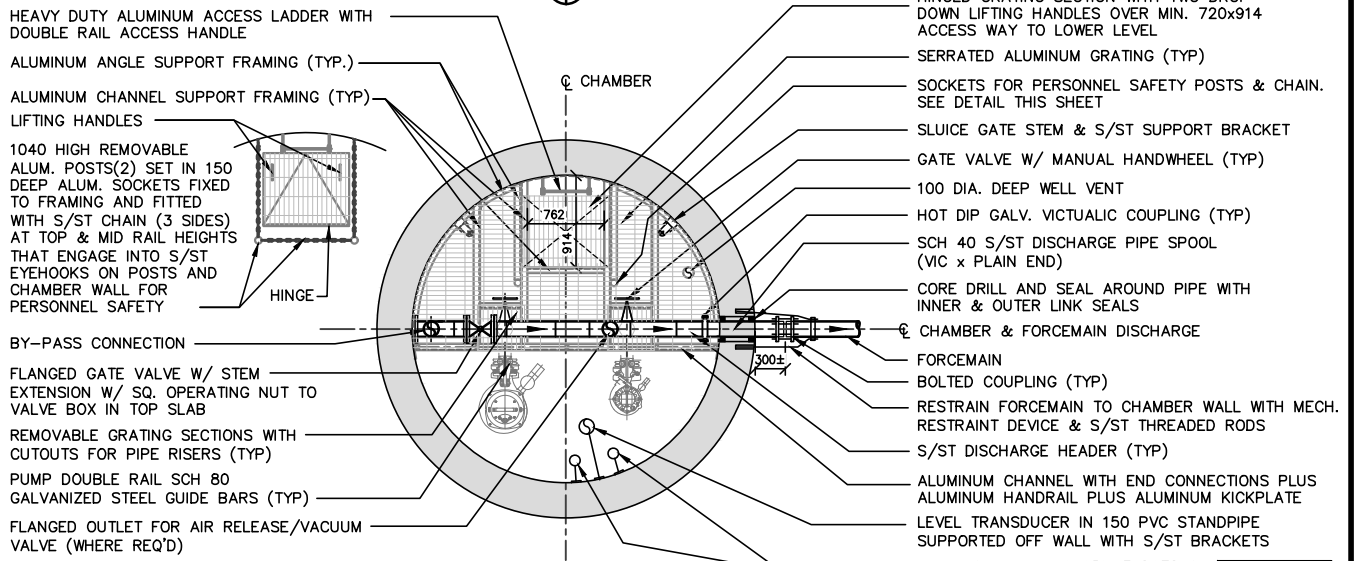

TYPICAL PLATFORM PLAN

N.T.S.

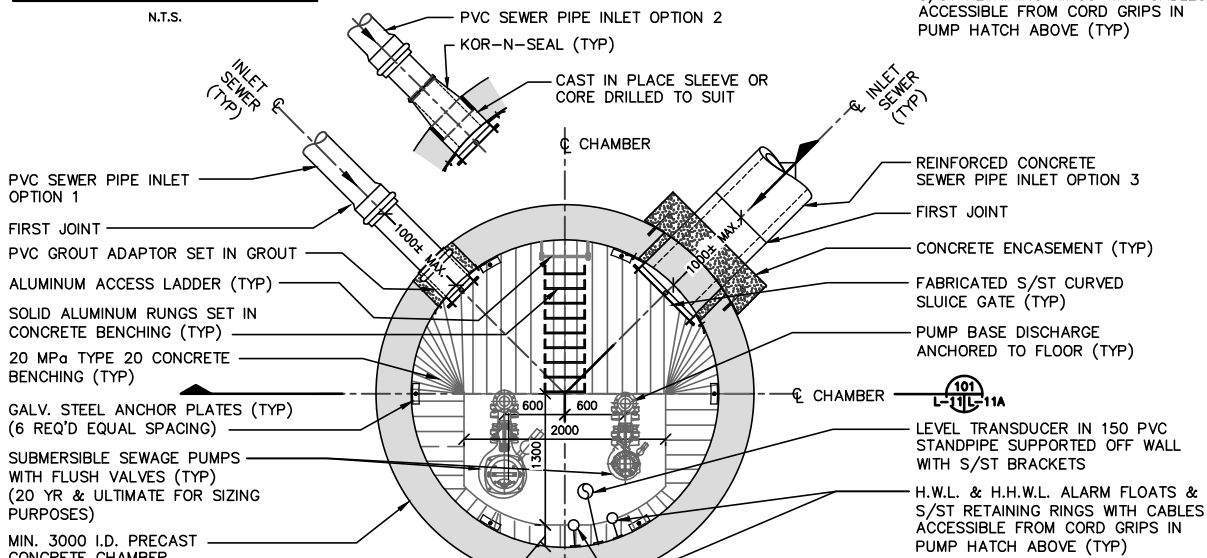

TYPICAL BASE PLAN

N.T.S.

NOTES:
ALL FASTENERS AND HARDWARE WITHIN CHAMBER TO BE MIN. TYPE 316 STAINLESS STEEL (S/S/T).

This standard drawing serves as a reference to assist the Engineer in the design and preparation of detailed construction drawings. Contemplated changes/deviations/customization of the design/arrangement/configuration depicted in this drawing to suit a specific design/situation/circumstance/location/etc. shall first be reviewed with and approved by the Town of Lakeshore on a case by case basis prior to implementation.



2	May 01, 2014
1	May 2009
No.	Revision Date

Town of Lakeshore Development Manual

Figure L-11
Typical Sanitary Pump Station (3000 DIA.)
Plan Views

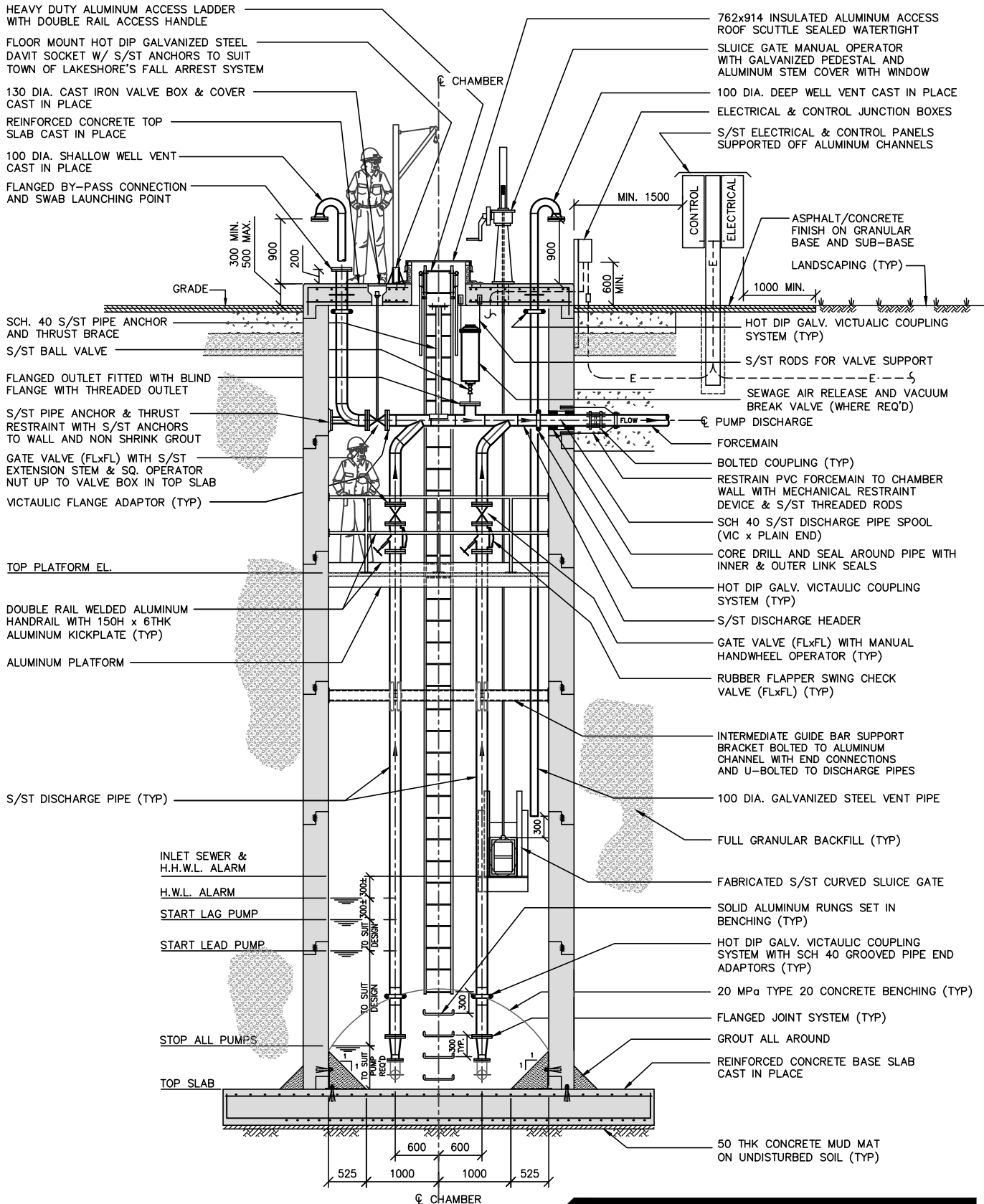

NOTES:
 ALL FASTENERS AND HARDWARE WITHIN CHAMBER TO BE MIN. TYPE 316 STAINLESS STEEL (S/ST).

This standard drawing serves as a reference to assist the Engineer in the design and preparation of detailed construction drawings. Contemplated changes/deviations/customization of the design/arrangement/configuration depicted in this drawing to suit a specific design/situation/circumstance/location/etc. shall first be reviewed with and approved by the Town of Lakeshore on a case by case basis prior to implementation.



2	May 01, 2014
1	May 2009
No.	Revision Date

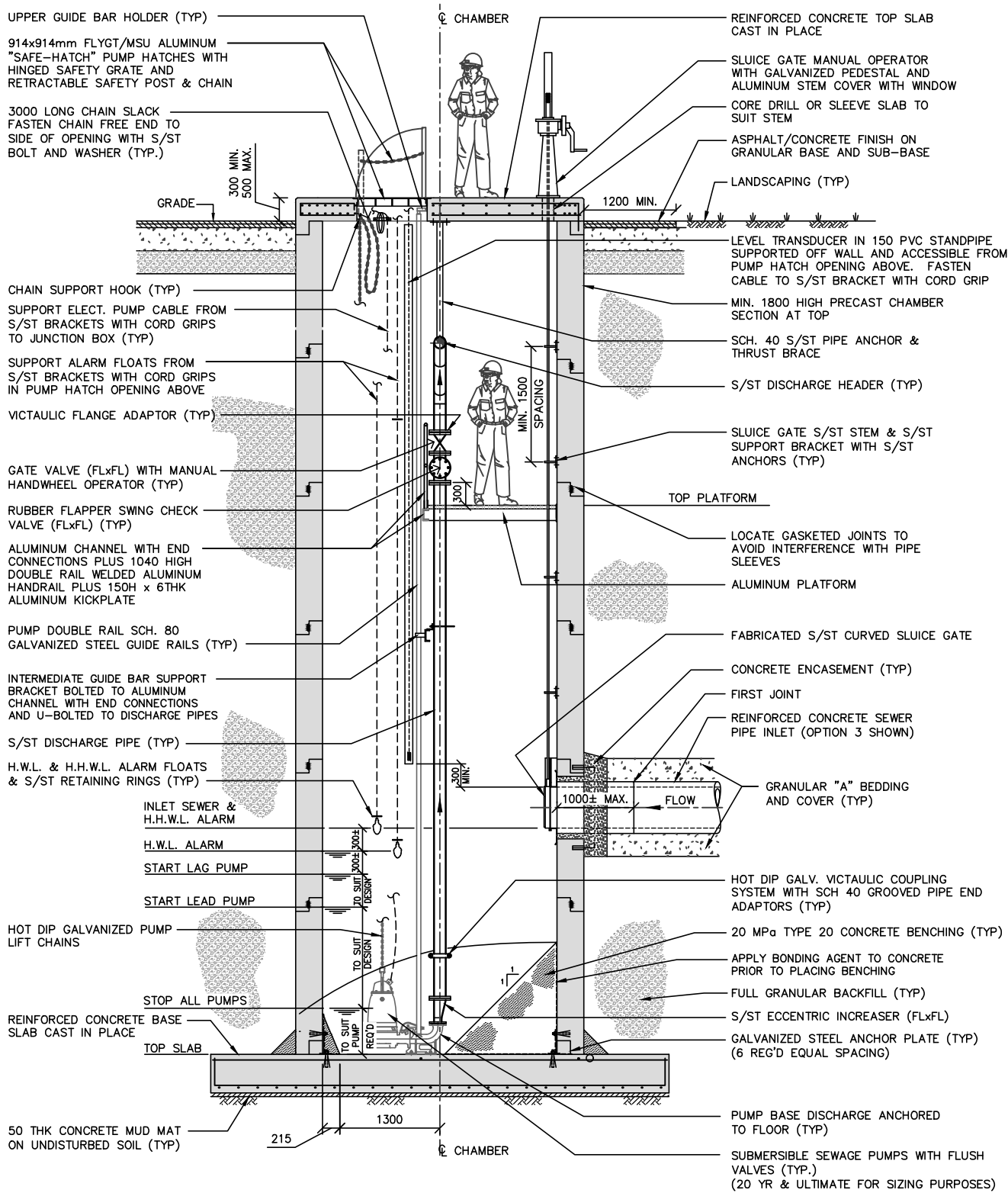

NOTES:
 ALL FASTENERS AND HARDWARE WITHIN CHAMBER TO BE MIN. TYPE 316 STAINLESS STEEL (S/ST).

This standard drawing serves as a reference to assist the Engineer in the design and preparation of detailed construction drawings. Contemplated changes/deviations/customization of the design/arrangement/configuration depicted in this drawing to suit a specific design/situation/circumstance/location/etc. shall first be reviewed with and approved by the Town of Lakeshore on a case by case basis prior to implementation.



2	May 01, 2014
1	May 2009
No.	Revision Date

Town of Lakeshore Development Manual
Figure L-11B
 Typical Sanitary Pump Station (3000 DIA.)
 Cross Section

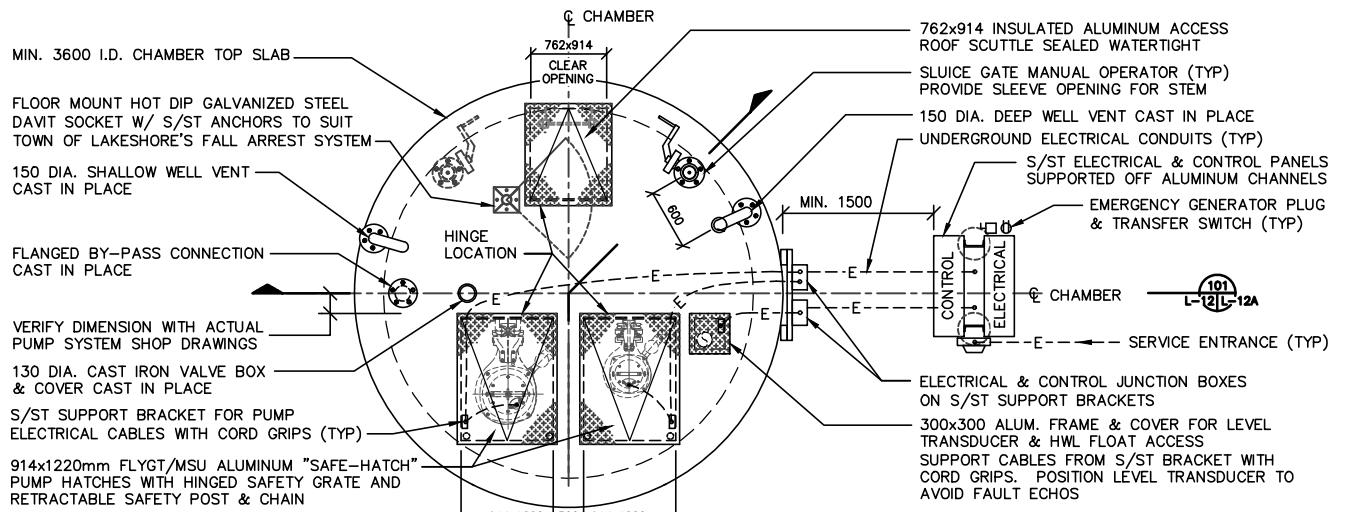

TYPICAL TOP PLAN

N.T.S.

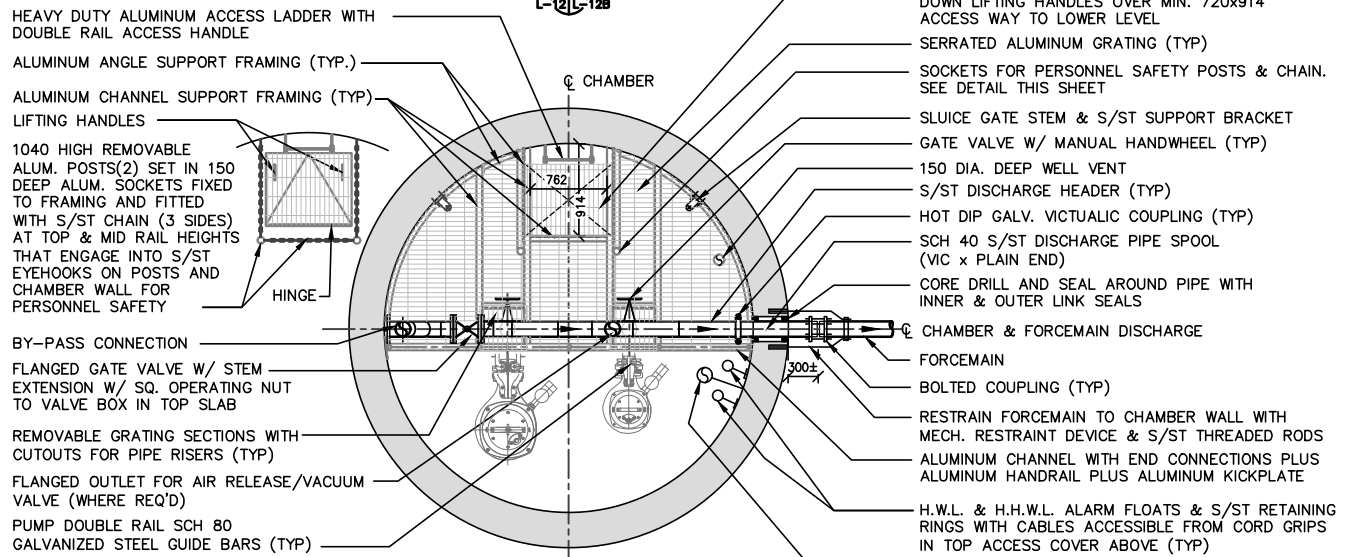

TYPICAL PLATFORM PLAN

N.T.S.

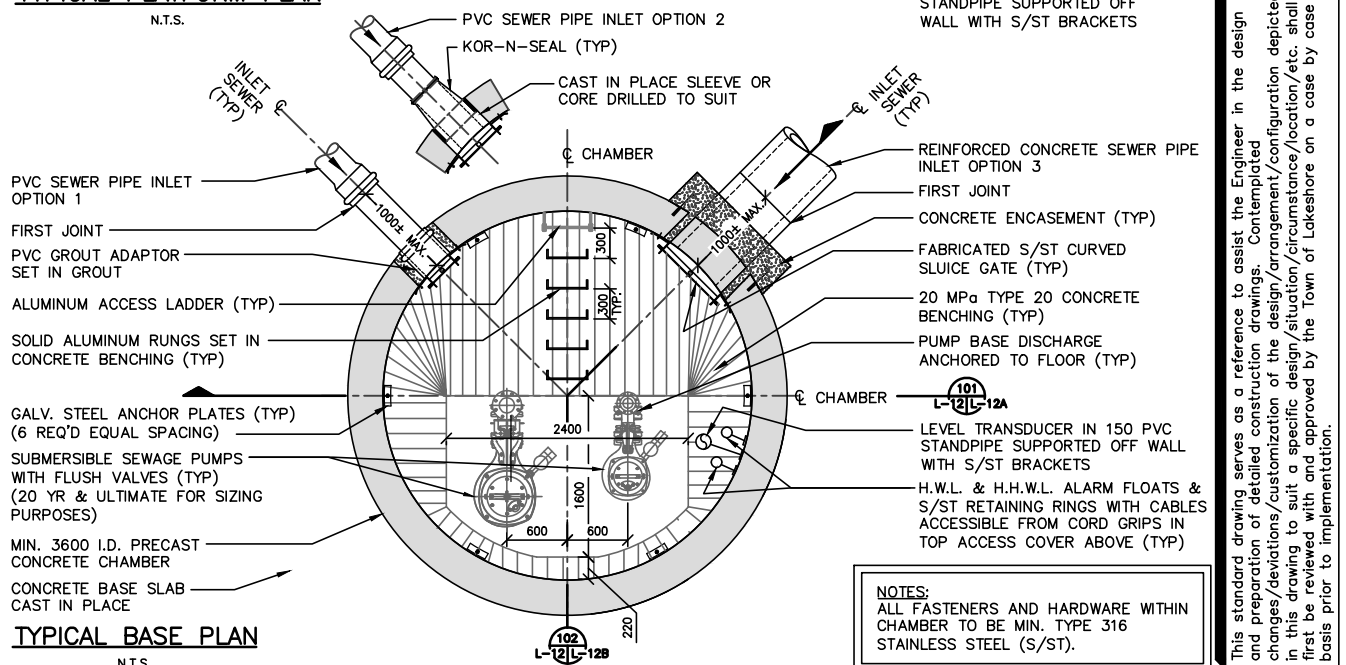

TYPICAL BASE PLAN

N.T.S.

NOTES:
ALL FASTENERS AND HARDWARE WITHIN CHAMBER TO BE MIN. TYPE 316 STAINLESS STEEL (S/ST).

This standard drawing serves as a reference to assist the Engineer in the design and preparation of detailed construction drawings. Contemplated changes/deviations/customization of the design/arrangement/configuration depicted in this drawing to suit a specific design/situation/circumstance/location/etc. shall first be reviewed with and approved by the Town of Lakeshore on a case by case basis prior to implementation.

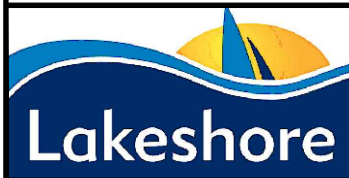

No.	2	May 01, 2014
	1	May 2009
		Revision Date

Town of Lakeshore Development Manual

Figure L-12
Typical Sanitary Pump Station (3600 DIA.)
Plan Views

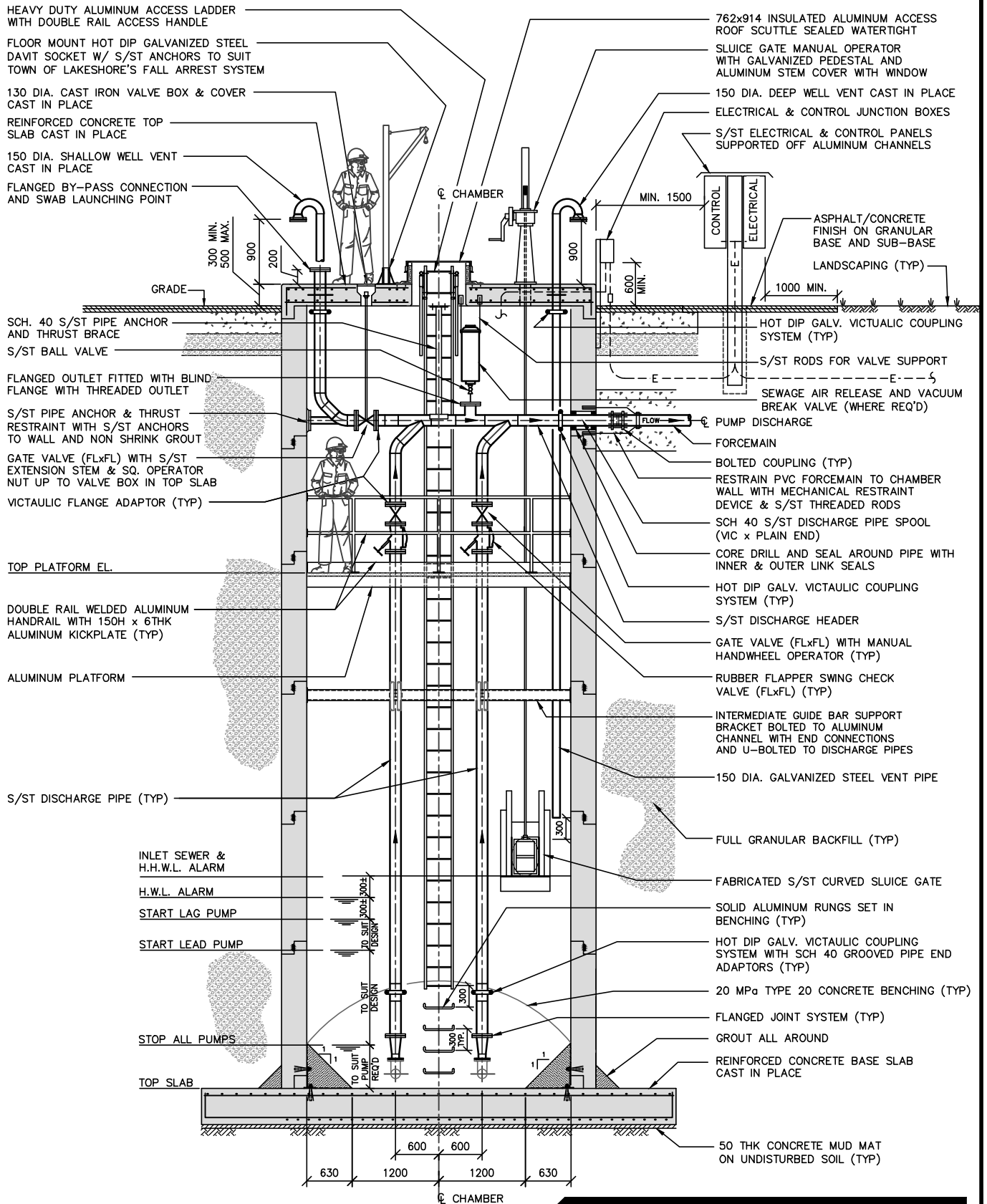

NOTES:
 ALL FASTENERS AND HARDWARE WITHIN CHAMBER TO BE MIN. TYPE 316 STAINLESS STEEL (S/ST).

This standard drawing serves as a reference to assist the Engineer in the design and preparation of detailed construction drawings. Contemplated changes/deviations/customization of the design/arrangement/configuration depicted in this drawing to suit a specific design/situation/circumstance/location/etc. shall first be reviewed with and approved by the Town of Lakeshore on a case by case basis prior to implementation.



2	May 01, 2014
1	May 2009
No.	Revision Date

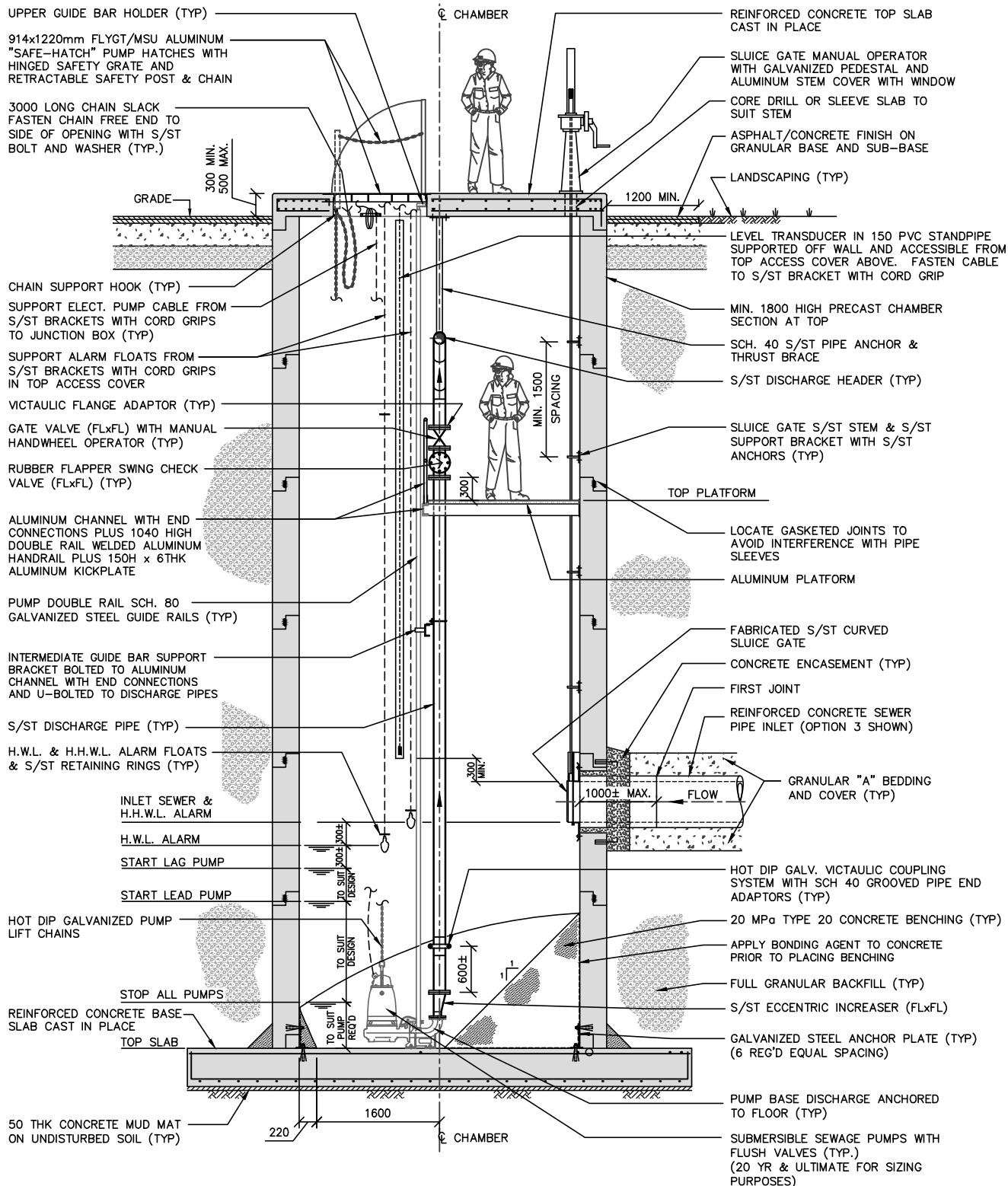

NOTES:
 ALL FASTENERS AND HARDWARE WITHIN CHAMBER TO BE MIN. TYPE 316 STAINLESS STEEL (S/ST).

This standard drawing serves as a reference to assist the Engineer in the design and preparation of detailed construction drawings. Contemplated changes/deviations/customization of the design/arrangement/configuration depicted in this drawing to suit a specific design/situation/circumstance/location/etc. shall first be reviewed with and approved by the Town of Lakeshore on a case by case basis prior to implementation.

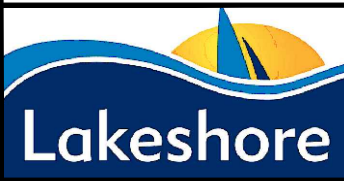

2	May 01, 2014
1	May 2009
No.	Revision Date

Town of Lakeshore Development Manual
Figure L-12B
 Typical Sanitary Pump Station (3600 DIA.)
 Cross Section

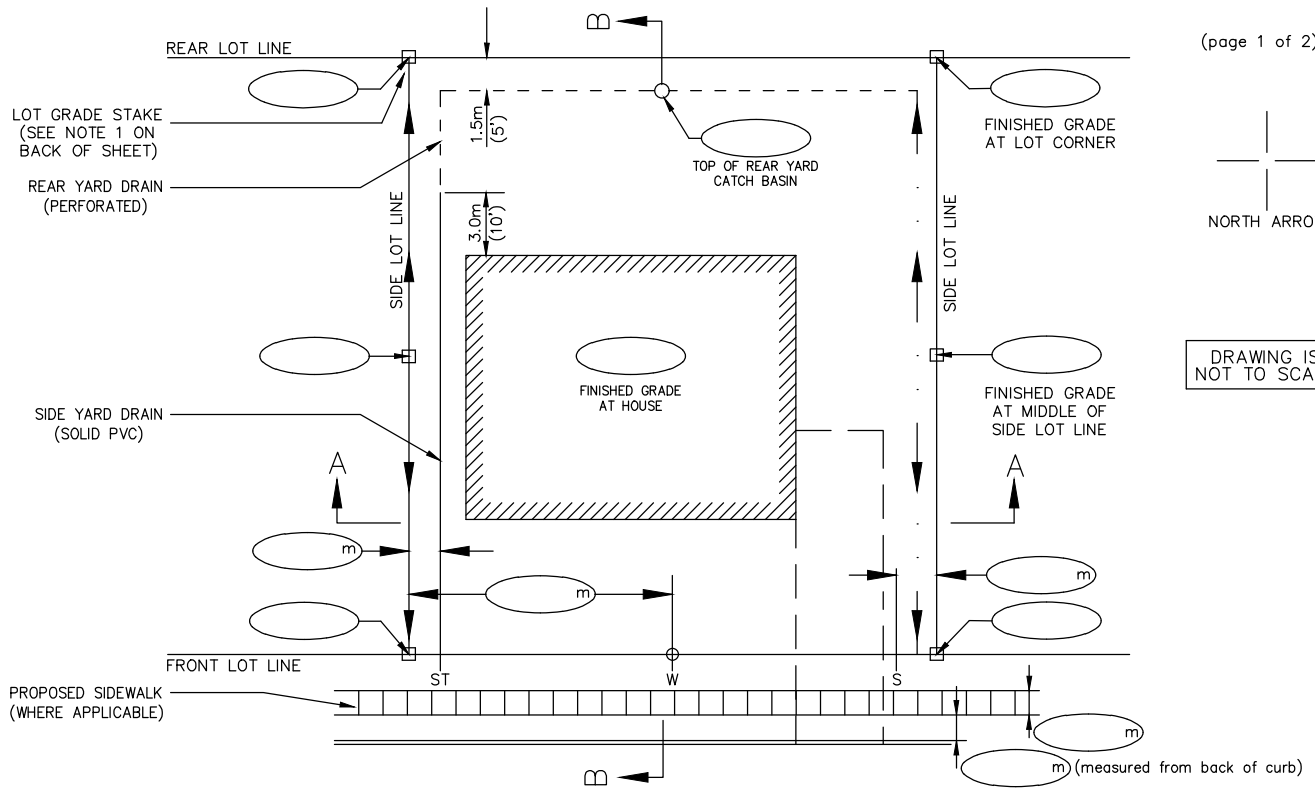

DRAWING IS NOT TO SCALE

ABUTTING SIDE YARD CONDITION
side yard swale on side lot line - grade to front and rear of lot

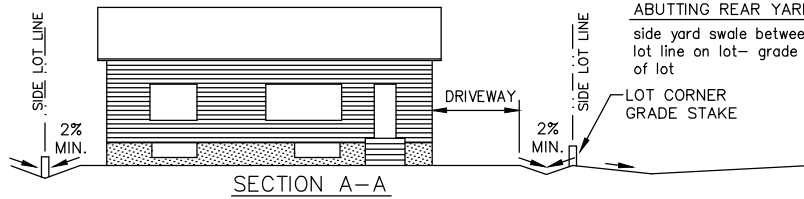

ABUTTING REAR YARD CONDITION
side yard swale between house and side lot line on lot - grade to front and rear of lot

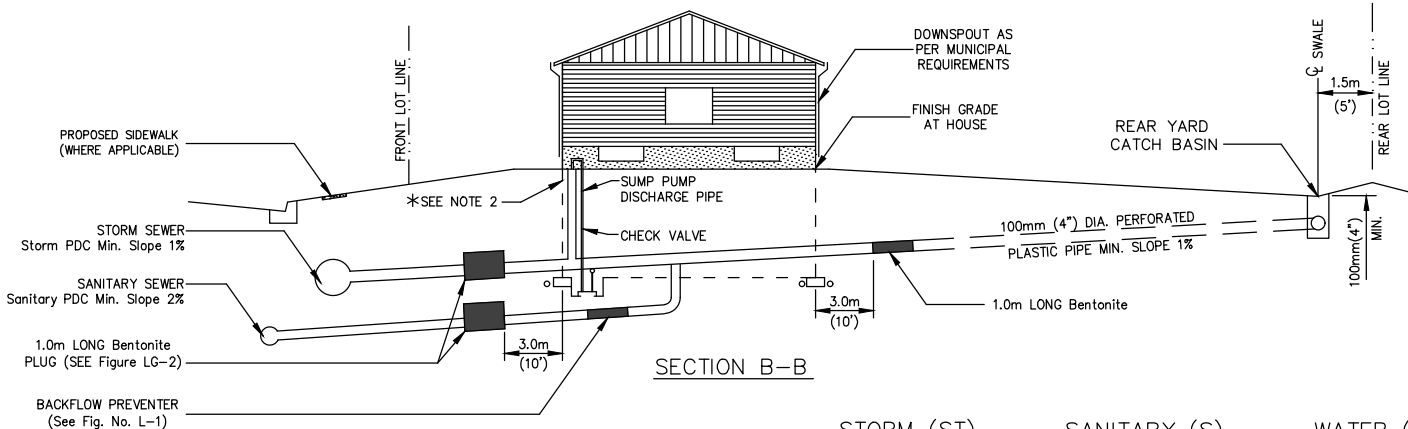

	STORM (ST)	SANITARY (S)	WATER (W)
SIZE:	150mm (6") DIA.	125mm (5") DIA.	25mm (1") DIA.
MATERIAL:	PVC	PVC	PE
INVERT AT R.O.W. LIMIT:			

CONSULTANT: _____
INSPECTOR: _____

I hereby certify that, to the best of my knowledge, the grades and elevations of the land within the lot, and locations and inverts of the services are accurate and in accordance with the measurements as shown above.

SIGNED: _____
DATE: _____

Municipal No. _____
LOT _____ Plan 12. _____ Part _____



No.	Revision Date
5	April 8, 2019
4	January 27, 2014
3	December 07, 2011
2	January 14, 2008
1	October 16, 2006

Town of Lakeshore Development Manual

Figure LG-1

LOT GRADING AND SERVICE SHEET

NOTES:

1. Place a 38x89x1500mm long (2"x4"x5') wood stake at each lot corner and at side yards adjacent to house. Mark the cut or fill to finished grade from top of stake on each stake. All stakes to remain in place until Chief Building Official approves final lot grading.
2. Sump pump discharge pipe shall be connected to the private storm service at an elevation not less than 300mm (12") above finished grade at the house.

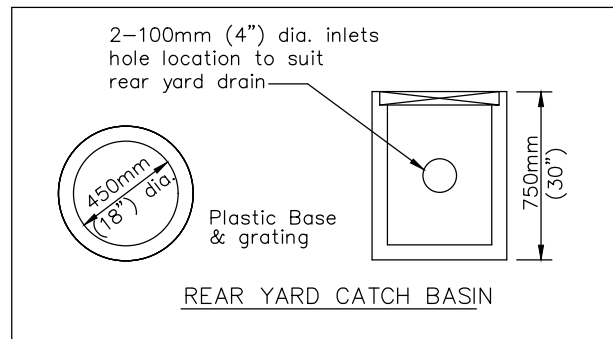
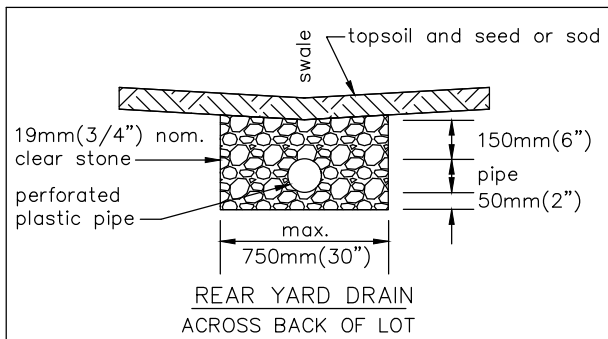
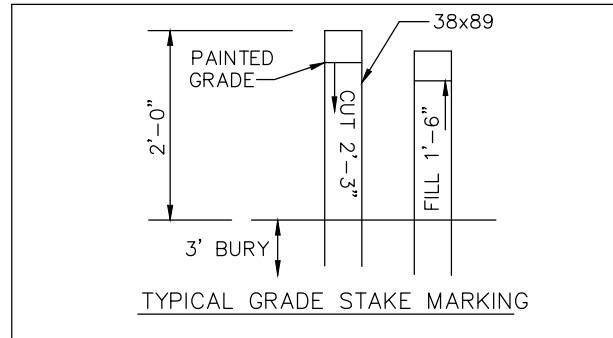
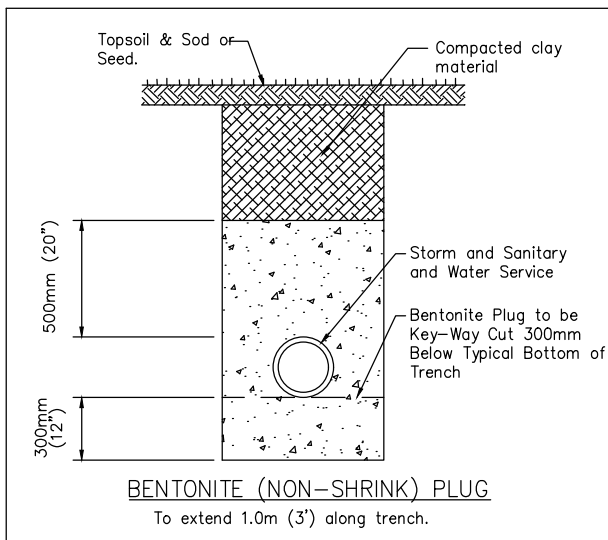

No.	Revision Date
4	April 8, 2019
3	December 07, 2011
2	January 14, 2008
1	October 16, 2006

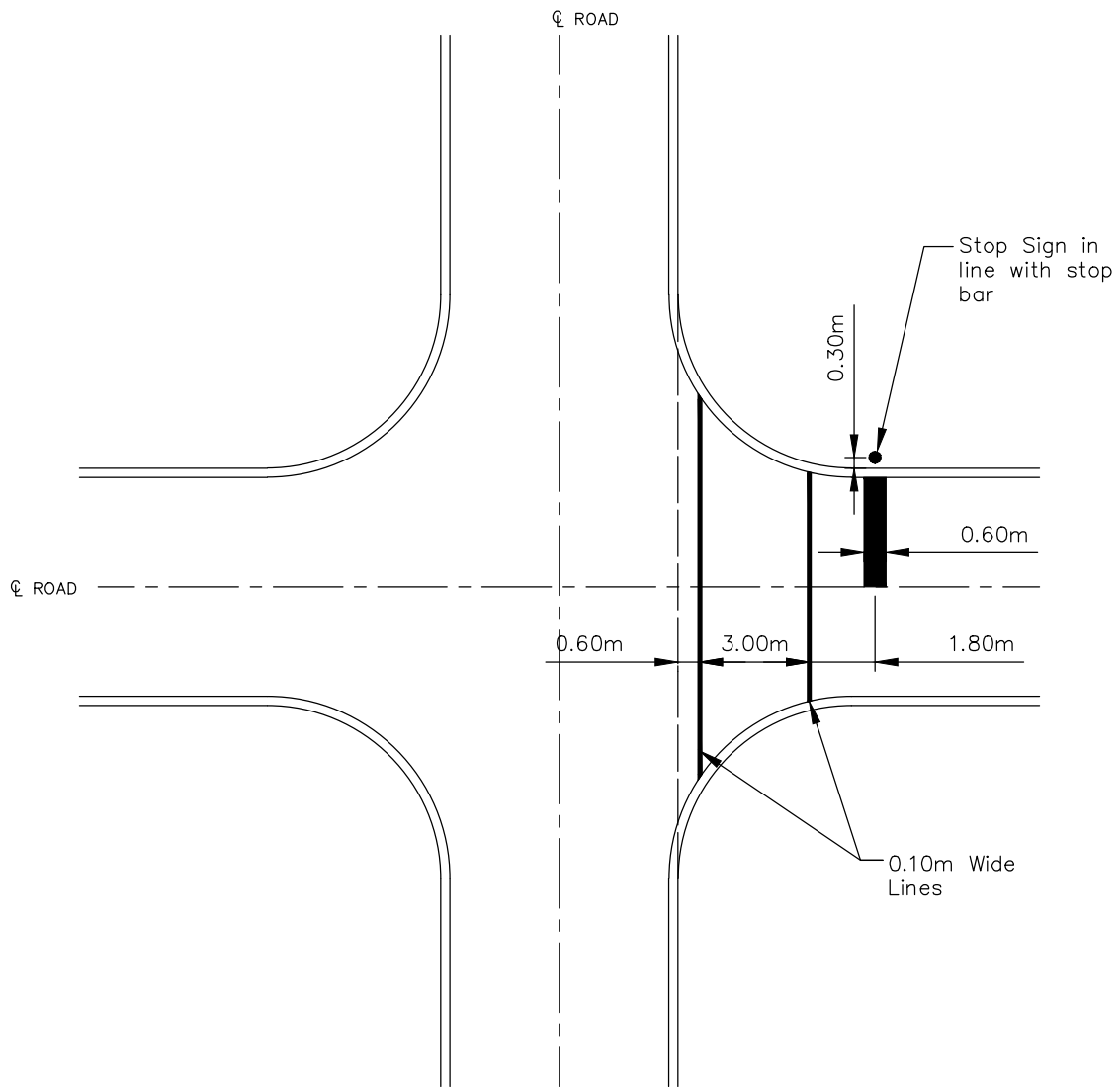

NOTE

1. All Dimensions are referenced to back of curb.



No.	Revision Date
1	October 16, 2006
2	January 14, 2008

Town of Lakeshore Development Manual

Figure R-1
TYPICAL CROSSWALK LINE PAINTING PLAN

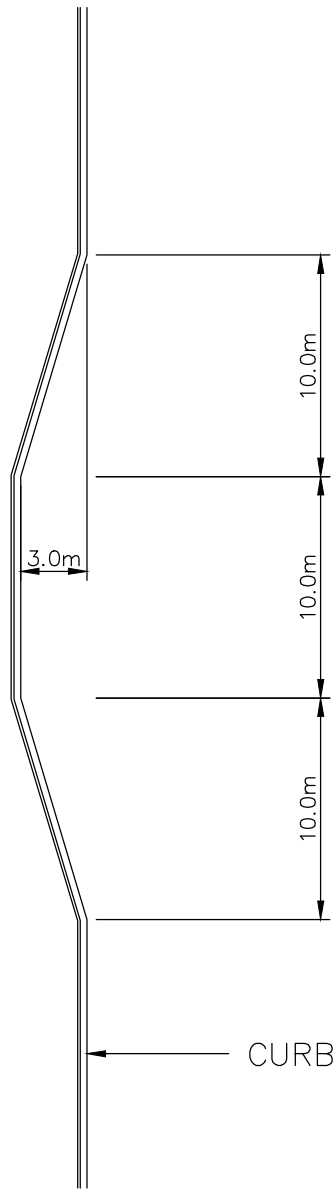

CURB



No.	Revision Date
1	October 16, 2006
2	January 14, 2008

Town of Lakeshore Development Manual

Figure R-2
TYPICAL COMMUNITY MAILBOX CAR BAY

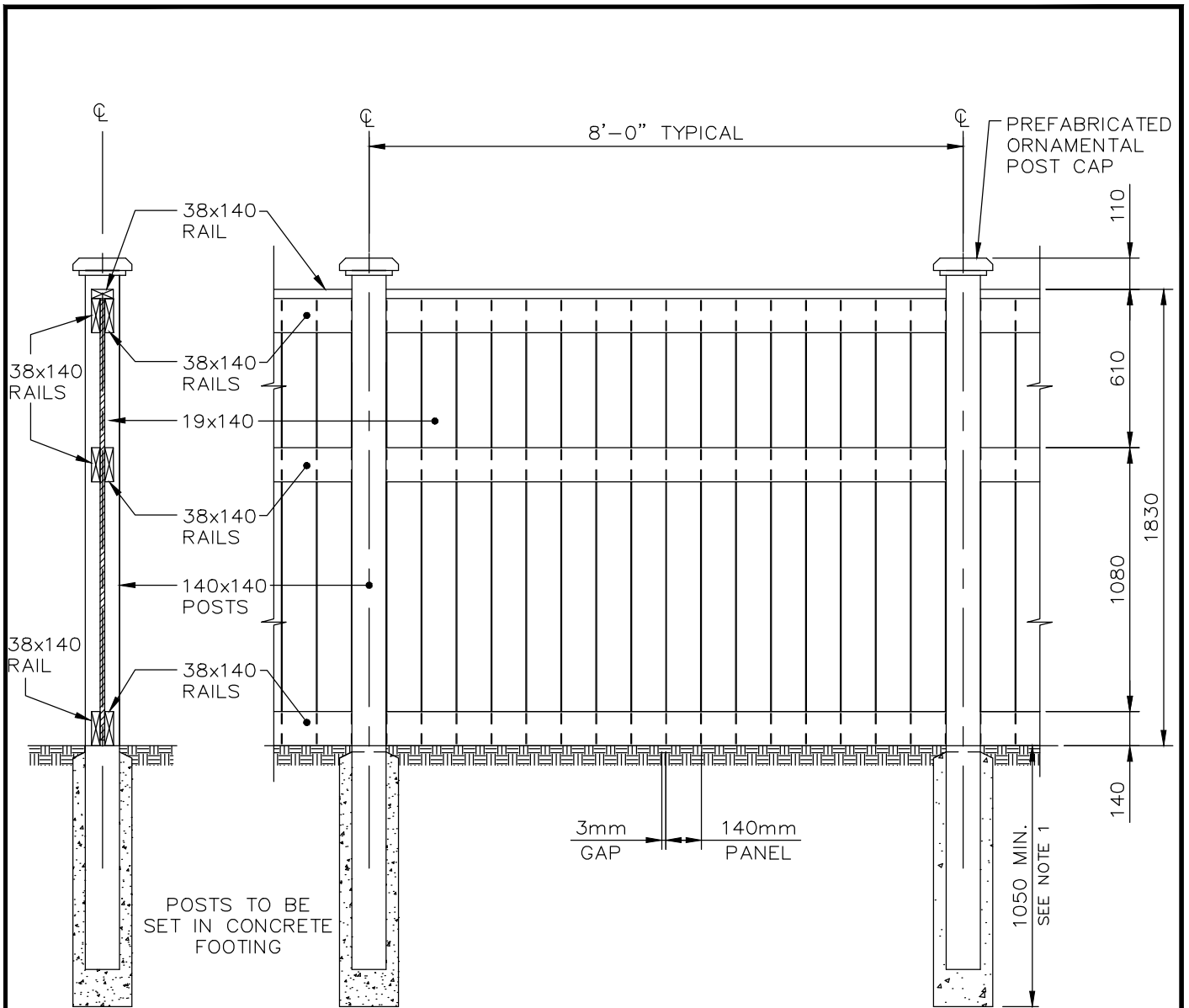

TYPICAL WOOD SCREEN FENCE PANEL
N.T.S.

NOTES

- 1 DESIGN TO BE COMPLETED BY A PROFESSIONAL ENGINEER.
- 2 ALL LUMBER TO BE PRESSURE TREATED WOOD. AFTER ERECTING FENCE, ALL CUT ENDS TO BE TREATED.
- 3 AS SUPPLIED BY CREATIVE HOMESCAPES OR APPROVED EQUAL.



No.	Revision Date
1	October 16, 2006
2	March 5, 2007
3	January 14, 2008
4	November 28, 2012
5	January 27, 2014

Town of Lakeshore Development Manual

Figure R-3
1830mm HIGH WOOD FENCE DETAIL

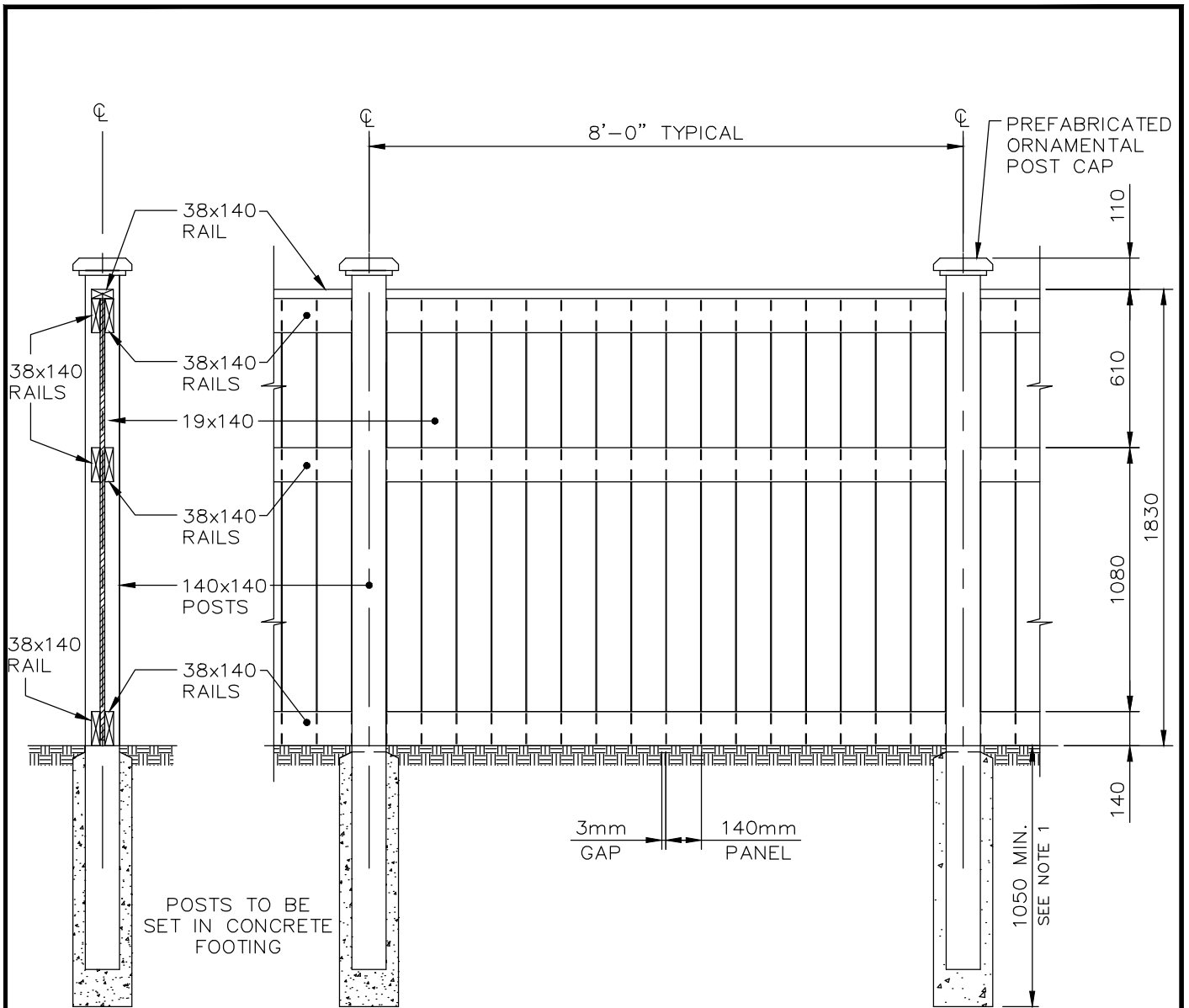

TYPICAL WOOD SCREEN FENCE PANEL
N.T.S.

NOTES

- 1 DESIGN TO BE COMPLETED BY A PROFESSIONAL ENGINEER.
- 2 ALL LUMBER TO BE PRESSURE TREATED WOOD. AFTER ERECTING FENCE, ALL CUT ENDS TO BE TREATED.
- 3 ALL FENCING COMPLETED AS PART OF A SUBDIVISION, SITE PLAN OR SERVICING AGREEMENT MAY NOT BE MODIFIED IN ANY WAY (i.e. ADDING GATES, HARDWARE, PAINTING, CUTTING, etc.) UNLESS REVIEWED AND APPROVED BY THE TOWN OF LAKESHORE PUBLIC WORKS DIVISION



6	March 3, 2019
5	January 27, 2014
4	November 28, 2012
3	January 14, 2008
2	March 5, 2007
1	October 16, 2006
No.	Revision Date

Town of Lakeshore Development Manual

Figure R-3
1830mm HIGH WOOD FENCE DETAIL

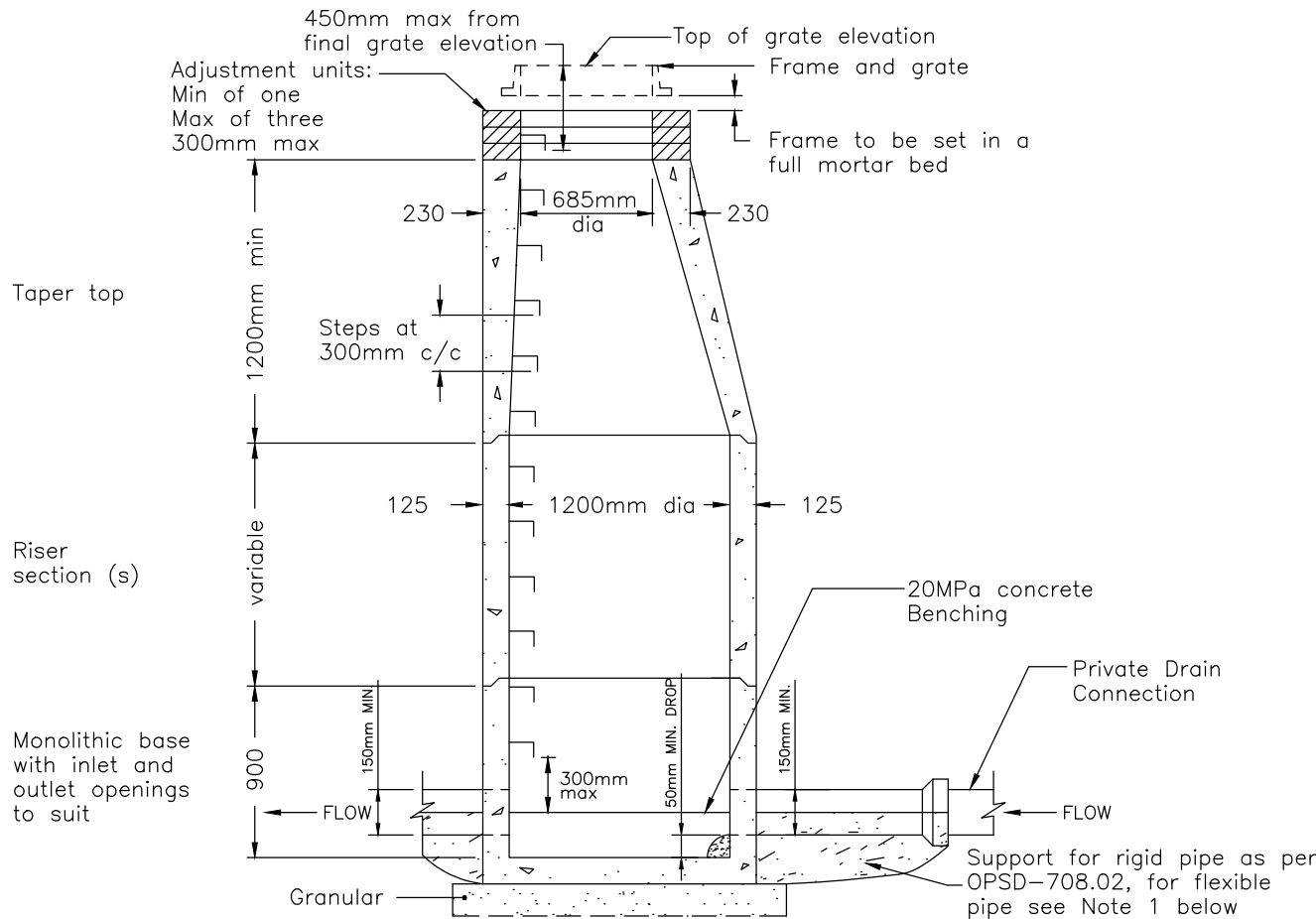

Bottom riser section with inlet and outlet openings to suit

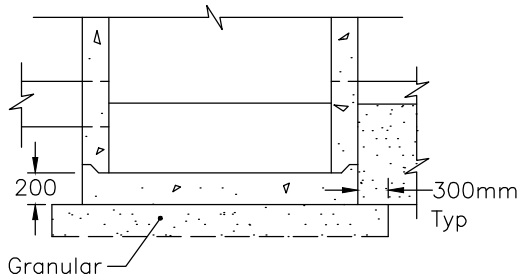

TYPE A
PRECAST SLAB BASE

ALTERNATIVES

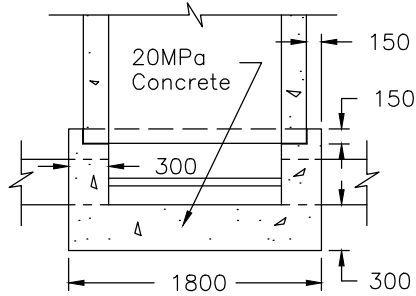

TYPE B
CAST IN PLACE BASE

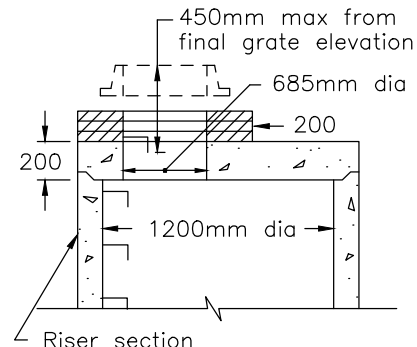

TYPE C
PRECAST FLAT TOP

Flexible joint 300mm max. from Manhole wall, in lieu of concrete cradle.

TYPE D

Approved flexible watertight pipe connector in MH opening in lieu of concrete cradle.

TYPE E

PIPE SUPPORT AT MANHOLE

NOTES:

- For flexible pipe use types 'D' or 'E' pipe support only.
- Granular backfill to be placed to a minimum thickness of 300mm all around.
- Special base design required for depths greater than 10.0m.
- Fill lifting holes and pipe connections and purge adjustment units on outside 15mm thick with 1:3 non-shrink mortar mix.
- Precast concrete components as per OPSD-701.03.
- Use alternative base, top, pipe support or connector, steps, frame and cover and/or benching where specified.
- Structures exceeding 5.0m in depth to include safety grate as per OPSD-404.02.
- All dimensions are in millimetres unless otherwise shown.



No.	Revision Date
2	January 14, 2008
1	October 16, 2006

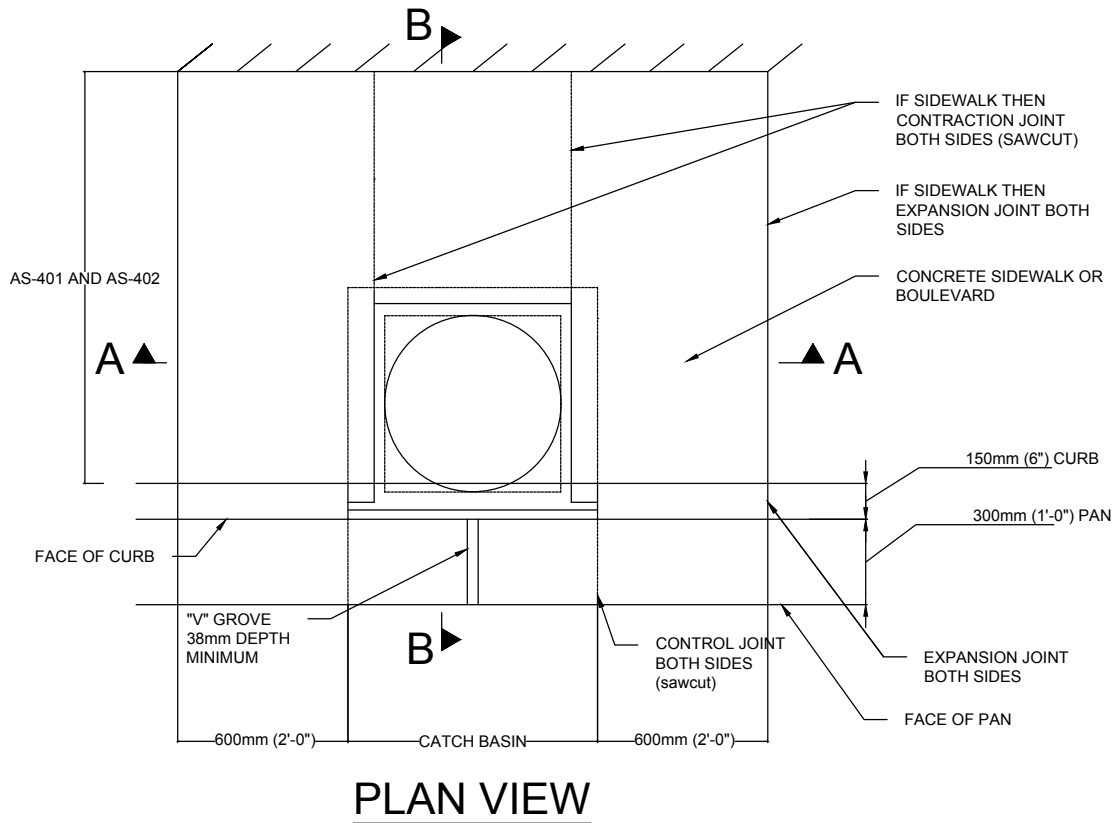

CATCH BASIN:

1. CATCH BASIN TO BE CENTERED WITHIN THE SIDEWALK BAY IF PLACED WITH SIDEWALK.
2. CONCRETE SIDEWALK THICKNESS SHALL BE 150mm FOR SIDEWALK BAY WITH CATCH BASIN.
3. FOR EXPANSION AND CONTRACTION JOINT DETAIL SEE OPSD 310.010.
4. CAST IRON CURB INLET FRAME ACCORDING TO OPSD 400.082.
5. "V" GROVE IN PAN TO ALLOW DRAINAGE DURING MAINTENANCE PERIOD PRIOR TO SURFACE ASPHALT COURSE BEING PLACED.
6. UNSHRINKABLE BACKFILL REQUIRED IN CATCH BASIN EXCAVATION.

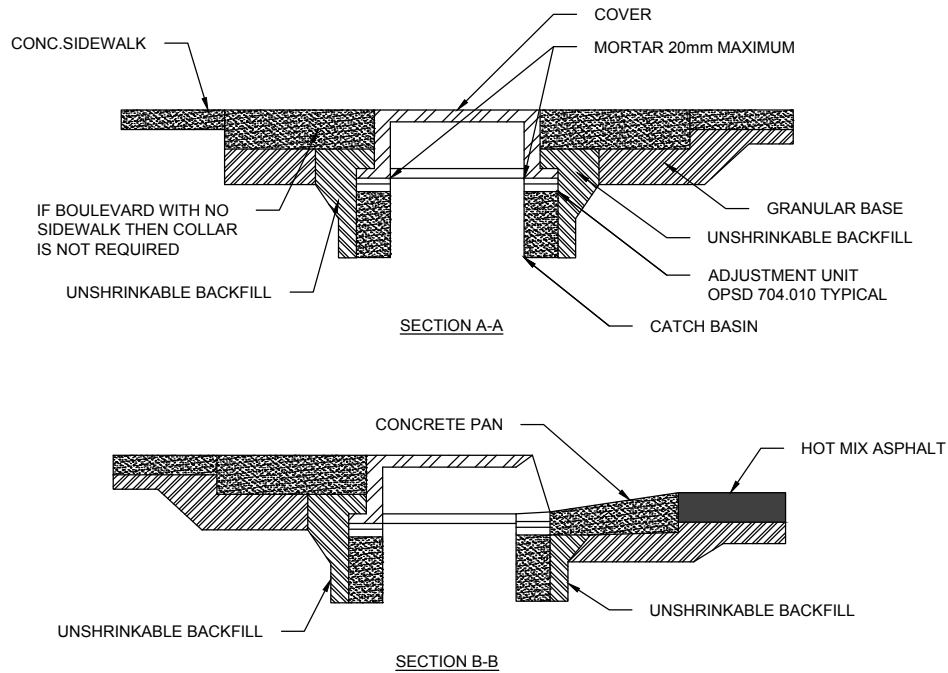

No.	Revision Date
2	July 7, 2017
1	December 2012

PIPE IN TRENCH

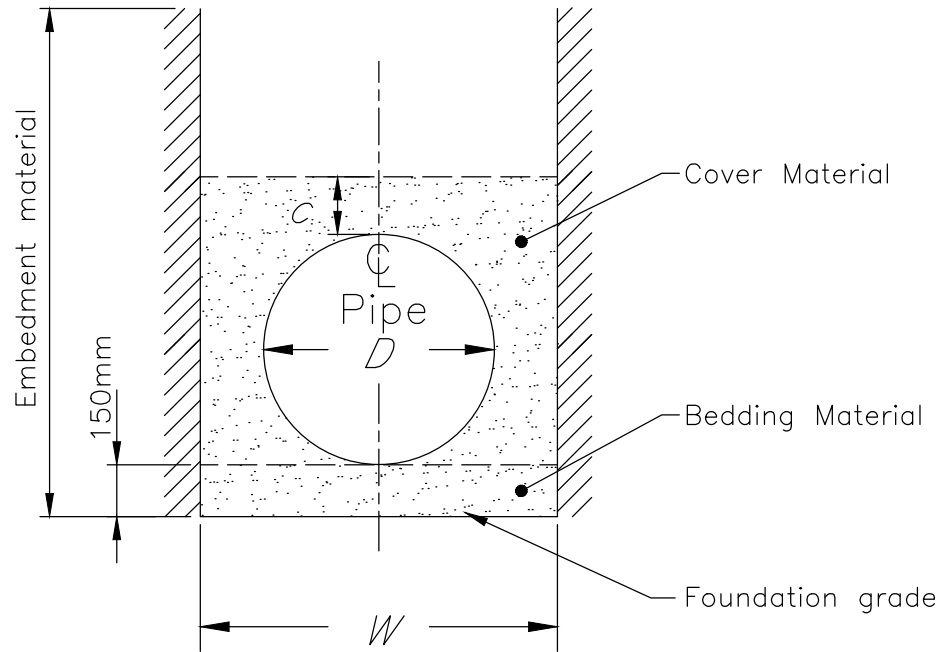

EARTH AND ROCK EXCAVATION

NOTES:

- 1 Backfill according to OPSD-803.04
- 2 All dimensions are in millimetres or metres unless otherwise shown.
- 3 Bedding material to be in accordance with the Ontario Building Code

LEGEND:

- D - Inside diameter
- W - Minimum width of bedding:
 $D + 800\text{mm}$ for $D \leq 1000\text{mm}$
 $1.67D$ for $1000\text{mm} < D < 1800\text{mm}$
 $D + 1200\text{mm}$ for $D \geq 1800\text{mm}$.
- c - Pipe Diameter $< 600\text{mm}$ $c = 300\text{mm}$,
 - Pipe Diameter $\geq 600\text{mm}$ $c = \frac{\text{Dia.}}{4} + 300$

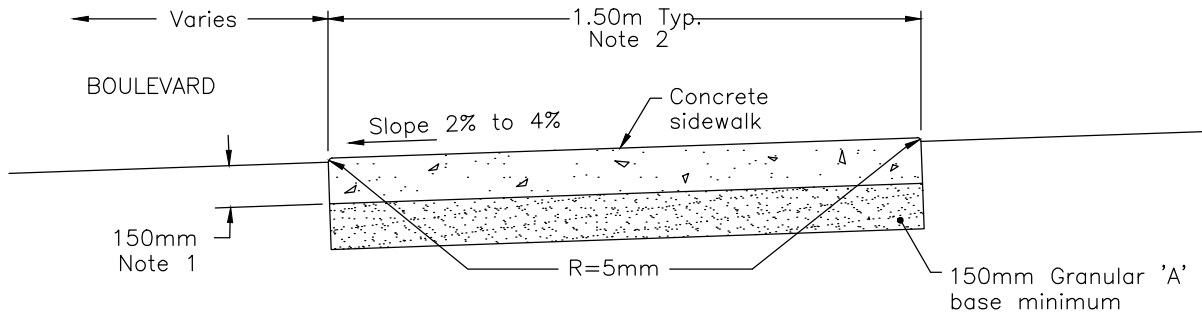

TYPICAL SECTION

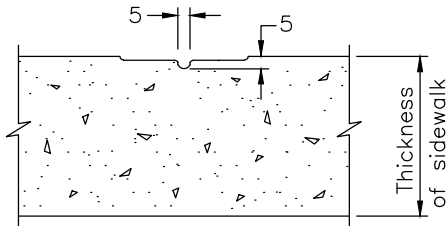

DUMMY JOINT

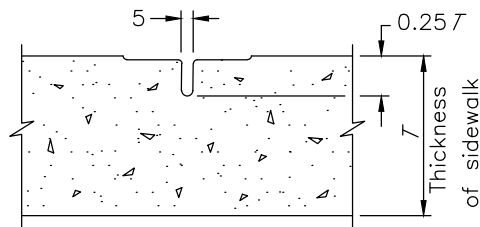

CONTRACTION JOINT

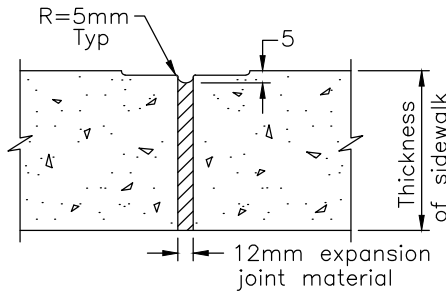

EXPANSION JOINT

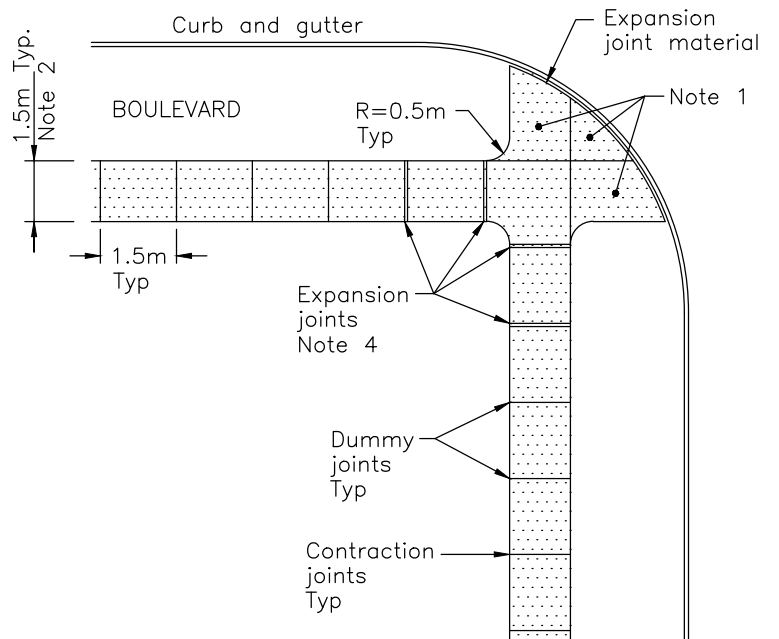

JOINT LAYOUT

NOTES:

- 1 Sidewalk thickness in residential areas shall be 150mm.
At commercial and industrial driveways, the thickness shall be 200mm.
- 2 Sidewalk width shall be increased at school areas, bus stops and other high pedestrian areas.

- 3 All dimensions are in millimetres or metres unless otherwise shown.
- 4 Expansion joints shall be spaced no more than 15m apart.

STANDARD BASED ON ONTARIO PROVINCIAL STANDARD DRAWING OPSD-310.010



No.	Revision Date
4	July 7, 2017
3	April 12, 2011
2	January 14, 2008
1	October 16, 2006

Town of Lakeshore Development Manual

Figure S-5

CONCRETE SIDEWALK

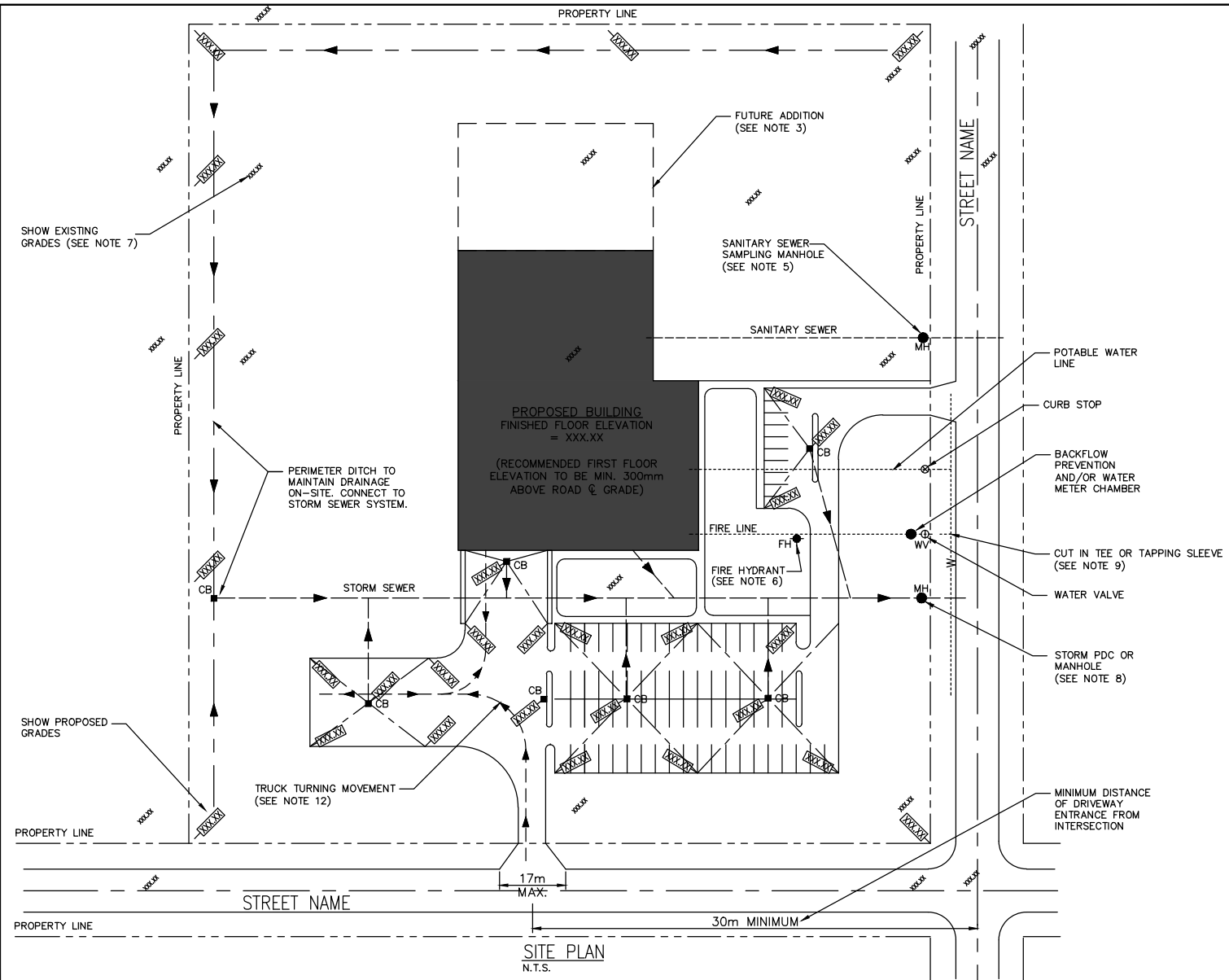

- GENERAL NOTES:**
1. Site services: Type, Size, Slope, Depth and Locations to be shown.
 2. Developer shall submit required studies as may be required for each development. (for list of possible studies required, see Development Manual Section 2.6).
 3. Future phasing to be shown if applicable.
 4. All property lines and easements shall be accurately shown and dimensioned.
 5. Sanitary Sampling Manhole as per figure S-1 located at property line.
 6. Existing Fire Hydrant locations to be shown and submission made to Town of Lakeshore Fire Chief for approval. Fire Hydrants to have Storz couplings.
 7. Existing grades to be shown on this lot and adjacent property. Also indicate finished floor elevation of adjacent buildings.
 8. Unless otherwise noted in subdivision servicing agreement, control storm water runoff rates to pre-development conditions, orifice located in manhole at property line preferred. (Submit Calculations).
 9. Connections to existing watermains to be cut-in-tees or tapping sleeves and valves at the Town's discretion. Inspection of water tie in to be organized through the Town of Lakeshore's Environmental Services Division.
 10. All work on public Right-of-Way requires a street opening permit, restore to existing condition with full granular backfill ('A' or 'B') compacted to 100% S.P.D.
 11. Parking and driveways to be paved. (See Development Manual)
 12. Truck Turning Movements for loading and deliveries to be confined within private property. (No backing in off roadway). See zoning By-Law.
 13. Note use of building, (3.2.2 Ontario Building Code Classification). Occupant Load, sprinklered, combustible, non-combustible.
 14. See Development Manual for applicable Town Standards.
 15. As-Constructed Drawings are required. (To be submitted to the municipality).



No.	Revision Date
3	April 8, 2019
2	January 14, 2008
1	October 16, 2006

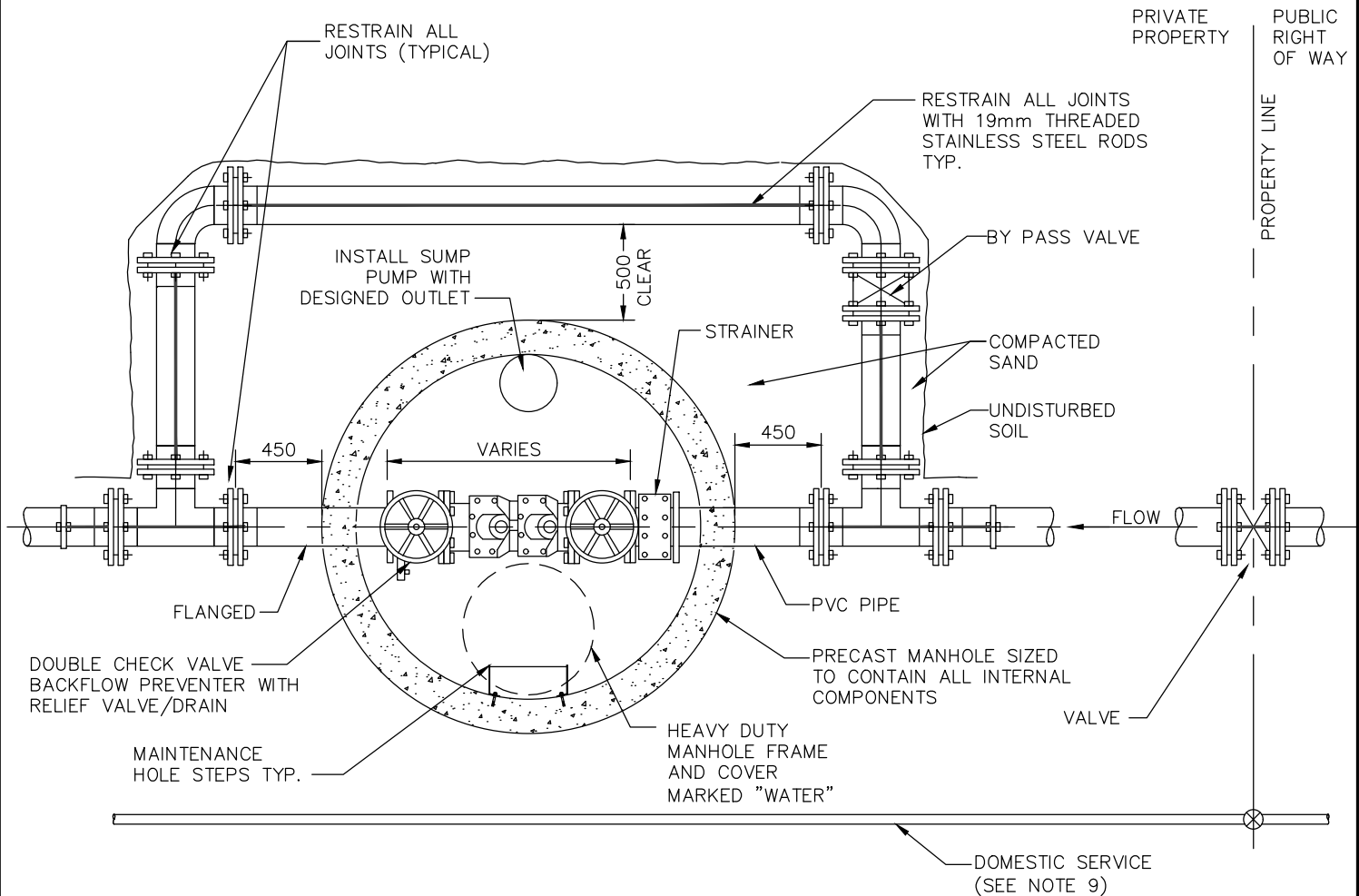

GENERAL NOTES

1. PRECAST CHAMBERS SHALL HAVE 600mm CLEARANCE AROUND ALL PIPING FOR MAINTENANCE PURPOSES.
2. BACKFLOW PREVENTERS SHALL BE AS MANUFACTURED BY WATTS OR APPROVED EQUAL.
3. STRAINER DEVICE SHALL BE AS MANUFACTURED BY NEPTUNE OR APPROVED EQUAL.
4. PROPERTY LINE VALVES SHALL BE AS MANUFACTURED BY MUELLER OR APPROVED EQUAL.
5. REMOTE READER SHALL BE APPROVED BY TOWN OF LAKESHORE
6. MANHOLES DESIGNED TO CARRY CL-625-ONT TRUCK TO CANADIAN HIGHWAY BRIDGE DESIGN CODE, CAN/CSA-S6-00
7. MANHOLE RUNGS TO BE AS PER OPSD 405-020
8. STAMPED SHOP DRAWINGS BEARING THE SEAL OF A PROFESSIONAL ENGINEER OF ONTARIO TO BE SUBMITTED
9. DOMESTIC WATER SERVICE TO BE CONNECTED SEPARATELY TO WATERMAIN ON PUBLIC RIGHT-OF-WAY.



No.	Revision Date
4	March 1, 2019
3	November 28, 2012
2	January 14, 2008
1	October 16, 2006

Town of Lakeshore Development Manual

Figure W-1
BACKFLOW PREVENTION

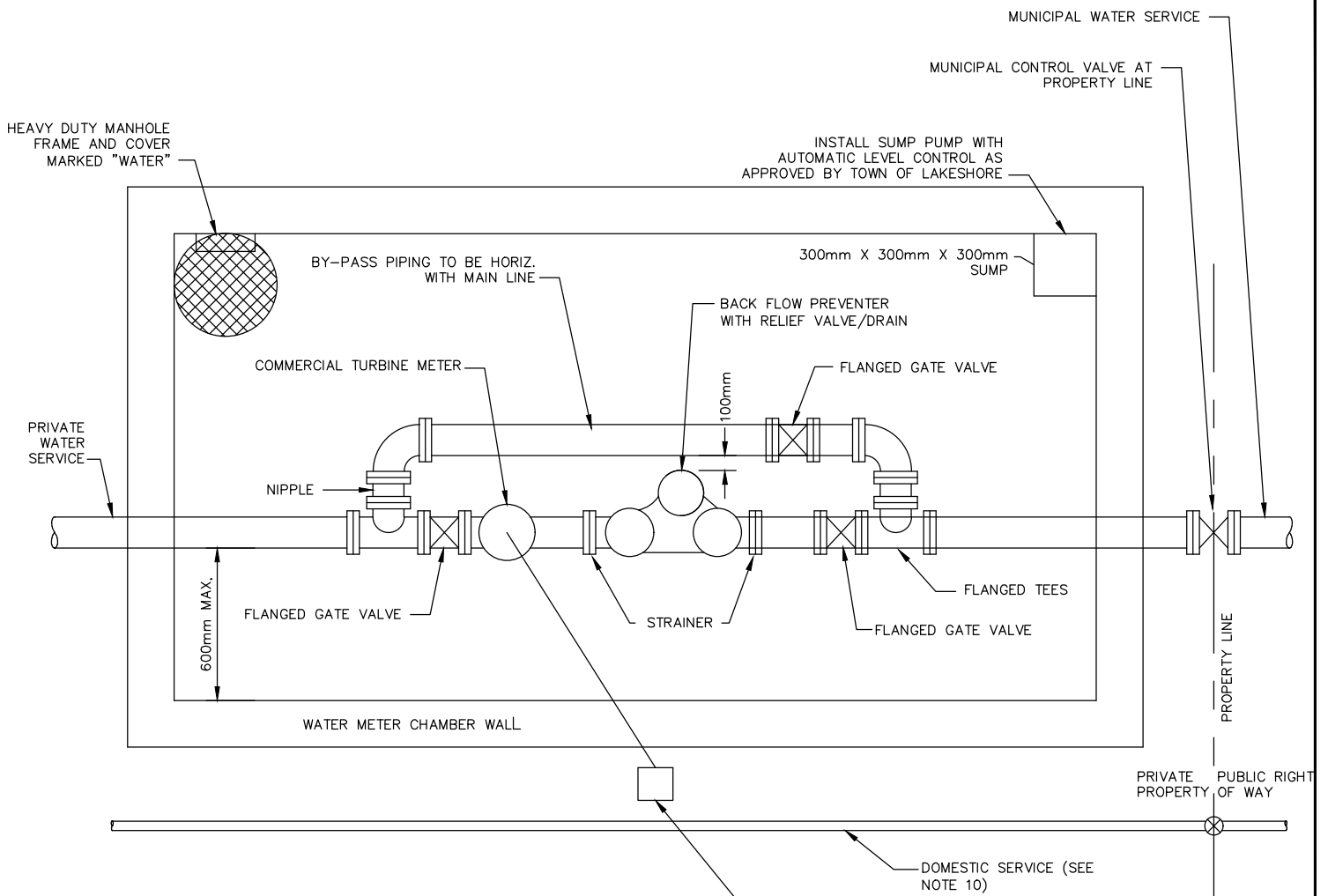

GENERAL NOTES

1. PRECAST CHAMBERS SHALL HAVE 600mm CLEARANCE AROUND ALL PIPING FOR MAINTENANCE PURPOSES.
2. METERS SHALL BE AS MANUFACTURED BY NEPTUNE OR APPROVED EQUAL.
3. BACKFLOW PREVENTERS SHALL BE AS MANUFACTURED BY WATTS OR APPROVED EQUAL.
4. STRAINER DEVICE SHALL BE AS MANUFACTURED BY NEPTUNE OR APPROVED EQUAL.
5. PROPERTY LINE VALVES SHALL BE AS MANUFACTURED BY MUELLER OR APPROVED EQUAL.
6. REMOTE READER SHALL BE APPROVED BY TOWN OF LAKESHORE WATER DISTRIBUTION DIVISION.
7. MANHOLES DESIGNED TO CARRY CL-625-ONT TRUCK TO CANADIAN HIGHWAY BRIDGE DESIGN CODE, CAN/CSA-S6-00
8. MANHOLE RUNGS TO BE AS PER OPSD 405-020
9. STAMPED SHOP DRAWINGS BEARING THE SEAL OF A PROFESSIONAL ENGINEER OF ONTARIO TO BE SUBMITTED
10. DOMESTIC WATER SERVICE TO BE CONNECTED SEPARATELY TO WATERMAIN ON PUBLIC RIGHT-OF-WAY.

100mm x 100mm x 2500mm LONG PRESSURE TREATED POST FOR REMOTE METER READING MIN. EMBEDMENT 1200mm BELOW GRADE

<u>MINIMUM CHAMBER SIZES</u>	<u>WIDTH</u>	<u>LENGTH</u>	<u>HEIGHT</u>
50mm DIA. WATER SERVICE	1.7m	3.0m	2.4m
100mm DIA. WATER SERVICE	2.1m	4.5m	2.4m
150mm DIA. WATER SERVICE	2.4m	5.1m	2.4m



No.	2	March 1, 2019
	1	October 16, 2006
		Revision Date

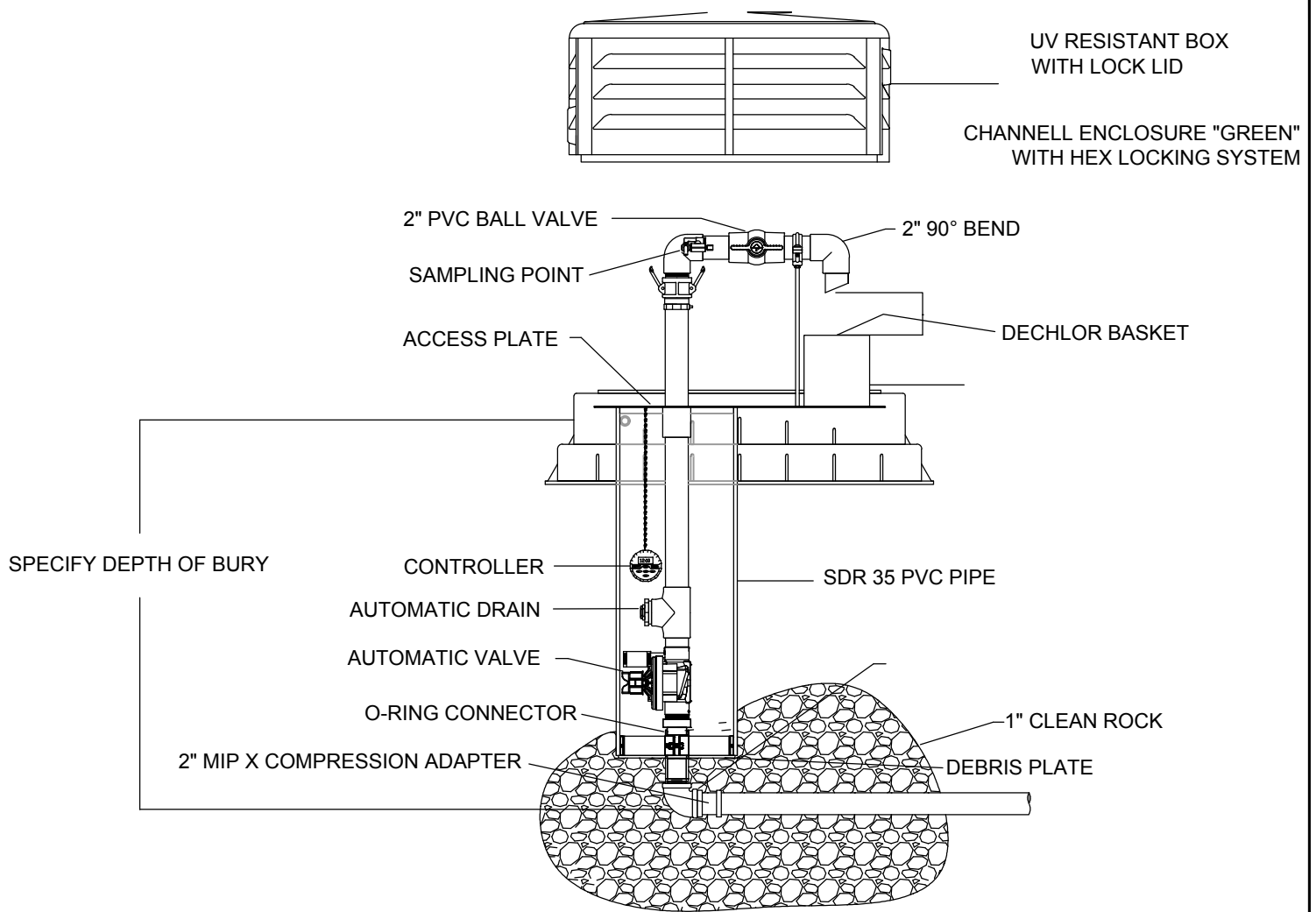

1. SUITABLE OUTLET FOR DISCHARGED WATER TO BE INCLUDED IN DESIGN
2. 2" BRASS FIP INLET, LEADING VERTICALLY INTO A 2" AUTOMATIC SOLENOID VALVE
3. AUTOMATIC SOLENOID VALVE SHALL HAVE A 150 PSI RATING
4. EACH UNIT SHALL BE FURNISHED WITH A STAND-ALONE VALVE CONTROLLER
5. CONTROLLER MUST HAVE MINIMUM OF 12 POSSIBLE FLUSHING CYCLES PER DAY, UP TO 6 HOURS PER FLUSH CYCLE AND SHALL BE SUBMERSIBLE TO 12 FEET, OPERATE WITH 9 VOLT BATTERY AND HAVE RESIN-SEALED ELECTRICAL COMPONENTS
6. SOLENOID SHALL HAVE NO LOOSE PARTS WHEN REMOVED FROM VALVE
7. EACH UNIT SHALL HAVE A DOUBLE-VALVE, ALL BRASS, SAMPLING POINT
8. REMOVAL OF 2" SOLENOID VALVE SHALL BE POSSIBLE VIA AN O-RING CONNECTOR LOCATED BENEATH THE VALVE AFTER DISCONNECTION OF STAINLESS STEEL ACCESS PLATE
9. VALVE ASSEMBLY SHALL BE HOUSED IN A PVC ENCLOSURE AND EACH UNIT SHALL BE SELF-DRAINING, NON-FREEZING, ALL ABOVE-GROUND COMPONENTS SHALL BE CONTAINED WITHIN A UV-RESISTANT LOCKING COVER

AS MANUFACTURED BY KUPFERLE FOUNDRY COMPANY. MODEL#9800 OR APPROVED EQUAL.

Note: Flush water lines free of debris before installation



No.	Revision Date
1	May 29, 2016
2	March 1, 2019

Town of Lakeshore Development Manual

Figure W-3
#9800 AUTOMATIC FLUSHING DEVICE

HYDRANT COLOUR CODE

499 G.P.M (US)
OR LESS
(RED)

500–999
G.P.M.(US)
(ORANGE)

1000–1499
G.P.M. (US)
(GREEN)

1500 G.P.M. (US)
OR GREATER
(LIGHT BLUE)

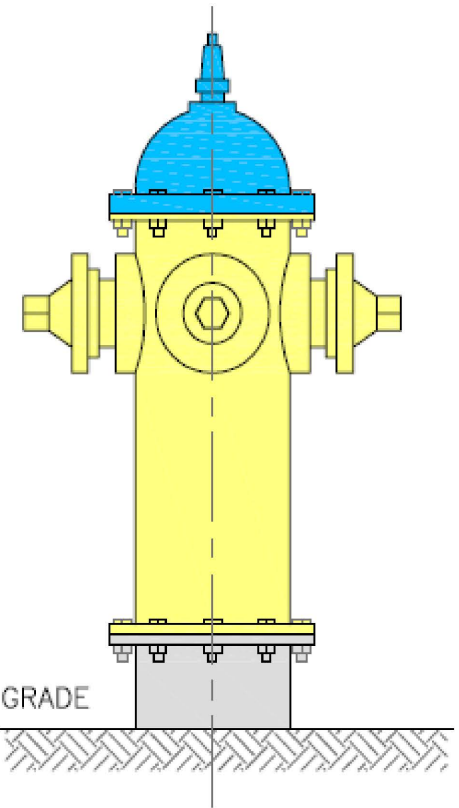
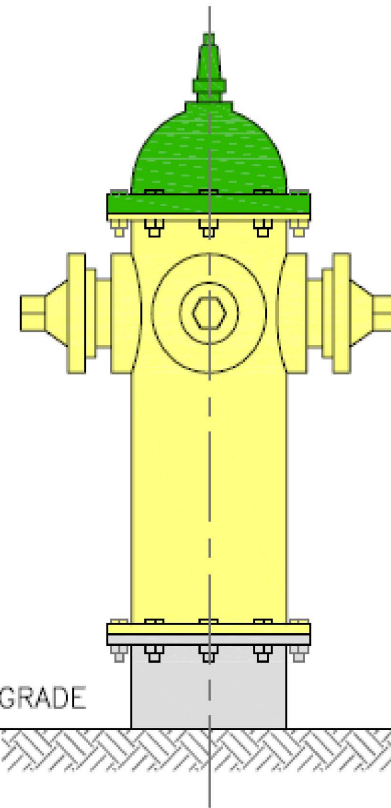
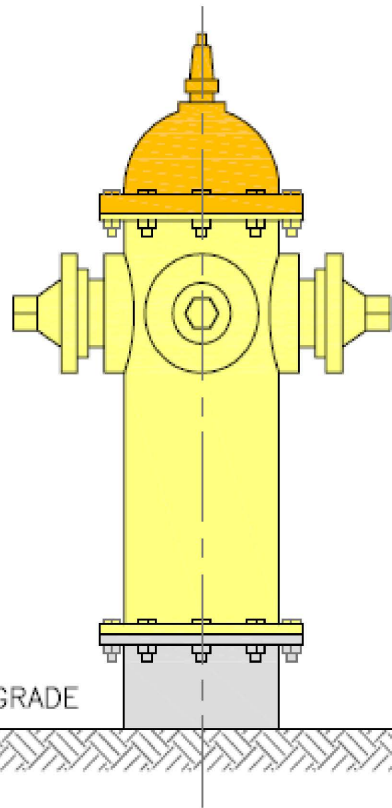
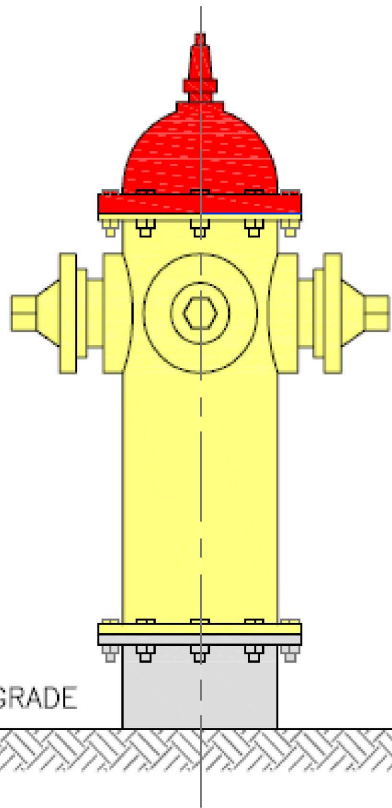

CLASS 'C'

CLASS 'B'

CLASS 'A'

CLASS 'A-A'

* Hydrant Colour Coding is as per NFPA 291



No.	Revision Date	No.	Revision Date
		1	July 6, 2017

Town of Lakeshore Development Manual

Figure W-4
Fire Hydrant Flow Test Colour Codes